

CABLE FESTOON SYSTEMS



CONDUCTIX
INSUL 8

© DELACHAUX GROUP

POWER AND DATA TRANSFER

Cable Festoon Systems - For Moving Machinery

CONDUCTIX offers a comprehensive range of Cable Festoon Systems to power moving machinery. Our festoon systems are ideal for supporting, protecting, and managing power and data cables, or air/fluid hoses. Whatever the particular cable/hose package or running speed, **CONDUCTIX** has the appropriate system for the job. Primary systems include:

- Light-duty Stretched Wire Systems
- Medium Duty I-Beam Systems
- Standard and Heavy-Duty C-Track Systems
- Heavy-Duty I-Beam Systems - designed for port container cranes and mill duty applications.
- Standard and Heavy-Duty Square Bar Systems

CONDUCTIX has custom-engineering systems also, so if you don't see what you need, contact us with your requirements. Check out the applications photos on the inside back cover of this catalog.

Cable Festoon Systems are available for indoor use, outdoor use, and hazardous or corrosive environments. Our systems are ideal for overhead cranes, gantry cranes, water treatment systems, car wash systems, bulk material conveyors, plating lines, and many other types of moving machines. Choose from a complete range of cable and festoon accessories, including cable connectors, tow cables/webbing, cable organizers, junction boxes, and push-button pendants. (See Pendant & Radio Catalog.)

CONDUCTIX Factory-Assembled Festoon Systems

5 important reasons to have **CONDUCTIX** factory-assemble your festoon system!

- Systems are assembled by experienced personnel under ideal factory conditions.
- Downtime is minimized and installation time and expenses are greatly reduced. Systems can be quickly transferred from the shipping channel to the machine channel.
- The festoon arrives "unitized" - no loose parts to handle. Small systems ship in a carton or crate. Large systems come in a steel shipping frame.
- The problems that can occur during field assembly are greatly reduced.
- Control trolleys (if ordered) are pre-wired to save installation time.



Standard C-Track in carton



Heavy-Duty C-Track in crate - with control trolley



Heavy-Duty I-Beam Festoon in Shipping Frame



System ready to be transported to job site



Installation on a container crane

Table of Contents

General Information and Pre-Assembled Systems	2
Festoon Specification Checklist & Technical Information	4-6
PVC Flat Cable & Connectors	7
Neoprene Flat Cable & Glands	8
Stretched Wire Rope Systems (load: 10 lbs./20 lbs. speed: 200 fpm.)	9
C-Track Systems	
Standard Duty (load: 40 lbs. speed: 250 fpm.)	10-13
Heavy-Duty (load: 80 lbs. speed: 500 fpm.)	14-16
Square Bar Systems	
Standard Duty (load: 45 lbs. speed: 250 fpm.)	17
Heavy-Duty (load: 150 lbs. speed: 250 fpm.)	18
Systems	18
Flat Cable Trolleys	19
Round Cable Trolleys	20
Medium-Duty I-Beam Systems	
Series 200 (load: 55 lbs. speed: 200 fpm.)	
Flat Cable Trolleys	21
Series 225 (load: 150 lbs. speed: 225 fpm.)	
Flat Cable Trolleys	22
Series 250 (load: 95 lbs. speed: 250 fpm.)	
Flat Cable Trolleys	23
Round Cable Trolleys	24
Series 350 (load: 175 lbs. speed: 350 fpm.)	
Flat Cable Trolleys	25
Round Cable Trolleys	26
Festoon Accessories & Junction Boxes	27-28
Push Button Pendants and Quick Disconnect Connectors	29
Heavy-Duty I-Beam Systems	30-31
System Overview	32-33
Application Information (see checklist on pgs. 4-5)	34
Cable Selection	34
Trolley Selection	35-36
System Calculations	37
Trolley Construction	38
10" (260 mm) Saddle	39
14" (360 mm) Saddle	40
19" (480 mm) Saddle	41
Auxiliary Saddle	42
Bumper Extensions	43
Running Gear	44-47
Accessories	
Tow Rope / Tow Chain	48-49
Shock Cords	50-51
Round Cable Organizer	52
Cable Separator	52
About CONDUCTIX	53
Terms & Conditions	54

Festoon Specification Checklist

Request Date: ___ / ___ / ___

Company: _____

Company Type? _____

Sales Person: _____

Contact: _____

Title: _____

Tel: _____

Fax: _____

e-mail: _____

Application Data

Estimated Installation Date: _____

Type of Crane: _____

Operating Speed: _____ fpm Acceleration Rate: _____

CMAA Crane Class*: A B C D E F Duty Cycle: _____ (24/7 etc.)

Type of System Req'd: Power Control Power & Control:

Crane Span: _____ ft. or Active Travel: _____ ft.

Loop Depth: _____ ft. or Max. Vertical Space Available: _____ ft.

Horizontal Storage Distance: _____ ft. or Storage Space Available: _____ ft.

* See pg. 6 for details

Environmental Data:

Indoors Outdoors Dusty Snow Ice

Chemicals: _____ Concentration: _____

Operating Temperature: Min _____ Max _____

Hazardous Location: Class _____ Div _____ Group _____

(Refer to NEC for details)

Cable Specifications

Hook up Length Needed: Fixed end _____ Mobile end _____

Cable List (Fill out table below or attach schedule)

	AWG	# of Cond.	Cable / Insulation Type
<input type="radio"/> flat <input type="radio"/> round			
<input type="radio"/> flat <input type="radio"/> round			
<input type="radio"/> flat <input type="radio"/> round			
<input type="radio"/> flat <input type="radio"/> round			
<input type="radio"/> flat <input type="radio"/> round			
<input type="radio"/> flat <input type="radio"/> round			
<input type="radio"/> flat <input type="radio"/> round			

Festoon Specification Checklist

Accessories / Options

Enclosures Required: Fixed End Mobile End:

If yes, NEMA Rating*: _____ Terminals Required: Yes No

Quick Disconnect Required: Fixed End Mobile End:

Tow Ropes: Yes No Tow Webbing: Yes No

For curved systems - please contact the factory

Pre-Assembly Requested: Yes No Pre-wiring Requested: Yes No

Side To Side Clearance Distance for Festoon System: _____

I-Beam Data (if festoon is mounted on I-Beam)

I-Beam Type/Size (if known): Size: _____ US
 European

List Beam Dimensions (if beam type / size is not known)

"S" TYPE BEAM

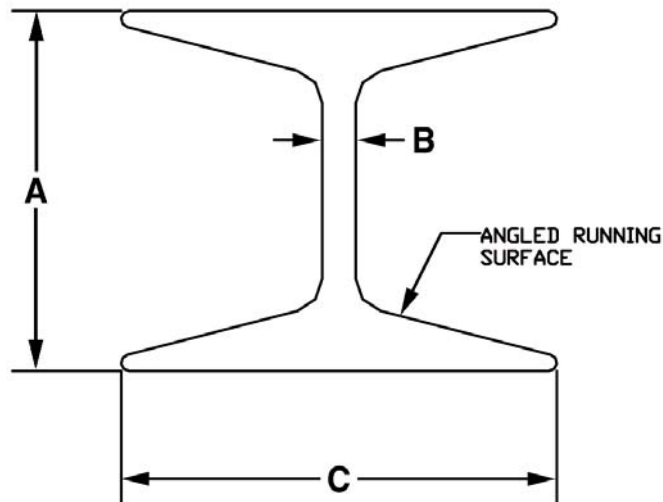

A= _____

B= _____

C= _____

"W" TYPE BEAM

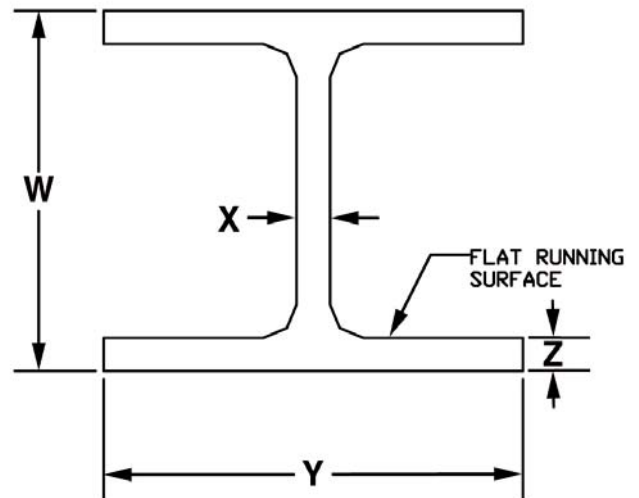

W= _____

X= _____

Y= _____

Z= _____

After completing form, please fax to 800-780-8329

Technical Information

CMAA Crane Classifications

Provided for general information only. Refer to CMAA Section 78-6 for full definitions.

Class A (Standby or Infrequent Service): Performs precise lifts at slow speed, with long idle period between lifts. Performs lifts at full or near rated capacity. Power houses, public utilities, turbine rooms.

Class B (Light Service): Light service requirements at slow speed. Performs 2 to 5 lifts/hour, light to occasional full loads, at 10 ft. average height. Repair shops, light assembly, service buildings, light warehousing.

Class C (Moderate Service): Moderate service requirement with loads averaging 50% of capacity. 5 to 10 lifts per hour at 15 ft. average lift height. Not more than 50% of lifts at rated capacity. Machine shops, paper mill machine rooms, etc.

Class D (Heavy Service): Bucket/magnet duty, where heavy duty production is required. Loads of 50% capacity handled constantly. 10 to 20 lifts per hour averaging 15 ft. lift height. Not over 65% of the lifts at rated capacity. Heavy machine shops, foundries, fabricating plants, steel warehouses, container yards, lumber mills, etc.

Class E (Severe Service): Loads approaching capacity throughout the life of the crane. 20 or more lifts per hour at or near rated capacity. Magnet/bucket cranes for scrap yards, cement mills, lumber mills, fertilizer plants, container handling.

Class F (Continuous Severe Service): Handles loads approaching capacity continuously under severe service conditions throughout the life of the crane. Includes custom designed specialty cranes performing work critical to the total production facility. Needs to have the highest reliability and ease of maintenance.

NEMA Enclosure Ratings

Provided for general information only. Refer to NEMA Standard 250 and IP AS 1939-1986 for full definitions.

Note: All enclosure types provide a degree of protection to personnel against incidental contact with the enclosed equipment.

NEMA 1 (IP10): Enclosures constructed for indoor use to provide a degree of protection against falling dirt

NEMA 2 (IP11): Enclosures constructed for indoor use to provide a degree of protection against falling dirt, and to provide a degree of protection against dripping and light splashing of liquids

NEMA 3 (IP54): Enclosures constructed for either indoor or outdoor use to provide a degree of protection against falling dirt, rain, sleet, snow, and windblown dust; and that will be undamaged by external formation of ice on the enclosure

NEMA 3R (IP14): Enclosures constructed for either indoor or outdoor use to provide a degree of protection against falling dirt, rain, sleet, and snow; and that will be undamaged by external formation of ice on the enclosure. (Enclosure can be vented.)

NEMA 4 (IP56): Enclosures constructed for either indoor or outdoor use to provide a degree of protection against falling dirt, rain, sleet, snow, windblown dust, splashing water, and hose-directed water, and that will be undamaged by the external formation of ice on the enclosure

NEMA 4X (IP56): Enclosures constructed for either indoor or outdoor use to provide a degree of protection against falling dirt, rain, sleet, snow, windblown dust, splashing water, hose-directed water, and corrosion; and that will be undamaged by the external formation of ice on the enclosure

NEMA 6 (IP67): Enclosures constructed for either indoor or outdoor use to provide a degree of protection against falling dirt; against hose-directed water, and the entry of water during occasional temporary submersion at a limited depth; and that will be undamaged by the external formation of ice on the enclosure.

NEMA 12 (IP52): Enclosures constructed (without knockouts) for indoor use to provide a degree of protection against falling dirt; against circulating dust, lint, fibers, and flying; and against dripping and light splashing of liquids.

NEMA 13 (IP54): Enclosures constructed for indoor use to provide a degree of protection against falling dirt; against circulating dust, lint, fibers, and flyings; and against the spraying, splashing, and seepage of water, oil, and non-corrosive coolants.

For information on hazardous location specifications, please contact the factory.

PVC Flat Cable & Connectors

Flat Cable

Required cable length = track length plus 10%, plus length required for end connections

Cable Part Number		Cable Size		Continuous Duty Rating at 30°C (86°F) Ambient Amps*	Short Time Rating Amps**		No. of Strands per Conductor	Weight per Foot (lbs.)	Nominal Dimensions Unshielded Cable (Inches)=
Yellow PVC Jacket	Shielded Flat Cable	Number of Conductors	AWG Wire Size		60 Min.	30 Min.			
23958Y		4	#2	120	148	173	665	1.27	.56" x 1.96"
26550Y		4	#4	90	111	130	420	.75	.49" x 1.70"
21814Y		4	#6	70	83	94	266	.60	.44" x 1.45"
26698Y		4	#8	50	63	69	168	.42	.37" x 1.19"
22542Y		4	#10	40	49	52	105	.24	.27" x .88"
22994Y		4	#12	30	36	40	65	.16	.23" x .71"
21815Y		4	#14	25	31	32	41	.12	.21" x .63"
26005Y		8	#12	21			65	.32	.23" x 1.34"
26110Y		8	#14	17	Control Cables		41	.22	.21" x 1.18"
22607Y	31772+	8	#16	15			65	.18	.20" x 1.11"
21813Y	34819+	12	#14	17	No Short		41	.34	.21" x 1.90"
23324Y	31580+	12	#16	15	Time Rating		65	.27	.20" x 1.61"
	31734+	4	#16				65	.16	.24" x .76"

- See NEC Table 16.14(A) Ampacity Correction Factors for temperatures above 30°C (86°F)
- For crane & hoist motors in accordance with article 610 of the 2005 National Electric Code for 90°C Cables.
- + Unshielded cable measurements may vary. Contact **CONDUCTIX** for shielded cable dimensions.
- All cables from #10 AWG through #16 AWG have rip cords for easy removal of the outer jacket.



Flat Cable Connectors

For termination of cable at power source or junction box.
Construction: Aluminum Body / Rubber Bushing



Catalog Number	No. of Cables	Cable Size		NPT	Ref Cable #
		No. of Cond.	Wire Size (AWG)		
35838	1	4	#4	2"	26550Y
35838B	1	4	#6	1.5"	26698Y
35837	1	4	#8	1.5"	26698Y
35835C	1	4	#10	1"	22542Y
35835B	1	4	#12	1"	22994Y
35835	1	4	#14	1"	21815Y
35837B	1	8	#12	1.5"	26005Y
35837C	1	8	#14	1.5"	26110Y
35837D	1	8	#16	1.5"	22607Y
35838C	1	12	#14	2"	21813Y
35838D	1	12	#16	2"	23324Y
35838G	2	8	#12	2"	26005Y
35837E	2	8	#14	1.5"	26110Y
35837F	2	8	#14	1.5"	22607Y

Catalog Number	No. of Cables	Cable Size		NPT	Ref Cable #
		No. of Cond.	Wire Size (AWG)		
35838E	2	12	#14	2"	21813Y
35838F	2	12	#16	2"	23324Y
35837G	1	8	#16	1.5"	22607Y
	1	4	#14	1.5"	21815Y
35837K	1	8	#14	1.5"	26110Y
	1	4	#14	1.5"	21815Y
35837J	1	8	#16	1.5"	22607Y
	1	4	#10	1.5"	22542Y
35837H	1	8	#14	1.5"	26110Y
	1	4	#10	1.5"	22542Y
35838H	1	12	#14	1.5"	21813Y
	1	4	#10	1.5"	22542Y
35837L	2	8	#16	1.5"	22607Y
	2	4	#12	1.5"	22994Y
35837M	2	8	#16	1.5"	26110Y
	2	4	#12	1.5"	22994Y

Heat Shrinkable Connections

For single cable and multiple cable groups, for flat and round cable

Corrosion Resistant ● Flame Retardant

Exceeds U.S. Navy requirements for tightness and integrity when used with one flat cable or multiple flat cables on the same size

Catalog Number	Cable Opening	Knockout Diameter	Dimension "A"	Weight lbs.
03147	1.60"	2.00"	6.17"	.40
03146	1.10"	1.37"	4.5"	.10
03145	.75"	1.00"	4.09"	.06

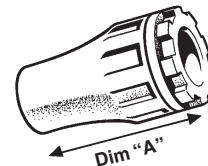

For the most current and up to date information visit our website at:

www.conductix.us

Neoprene Flat Cables & Connections

These cables are for use with festoon systems on cranes, hoists, and any other equipment with lateral transverse motion. They are suitable for indoor or outdoor applications where oil resistance and low-temperature flexing is required. The jacket is Neoprene rated at -40°C. to 90°C. and has U.V. inhibitor. The insulation for the awg-size cable is EPR rated at 90°C. The insulation for the metric-sized cable is Protolon EP.

Color Code:

4 conductor cables: green/yellow, black, blue, and brown

8-12 conductors: green/yellow, with all others black with numbers

Neoprene Flat Cable - AWG Sizes

Size - Awg	# of Cond	Ampacity at 45°C*	Part No.	# of Strands per Conductor	Thickness (in)	Width (in)	Wt. #/ft.
16	12	18	28151	76	0.260	1.787	0.24
14	12	24	28154	130	0.310	2.137	0.54
14	8	25	28153	130	0.295	1.500	0.39
14	4	27	28152	130	0.295	0.790	0.19
12	4	36	28155	211	0.343	0.976	0.29
10	4	47	28157	168	0.360	1.051	0.35
8	4	69	28158	287	0.414	1.252	0.52
6	4	94	28159	119	0.480	1.528	0.78
4	4	117	28160	186	0.563	1.799	1.05
2	4	157	28161	266	0.602	2.063	1.50
2/0	4	280	100698	333	0.770	2.630	2.60

Neoprene Flat Cable - Metric Sizes

Size - mm ²	# of Cond	Ampacity at 30°C*	Part No.	# of Strands per Conductor	Thickness (mm)	Width (mm)	Wt. Kg/m	Wt. #/ft.
1.5	12	14	103885	77	6.0	42.0	0.510	0.342
2.5	4	32	103888	130	7.0	20.0	0.270	0.181
2.5	12	19	102804	130	7.5	55.0	0.830	0.557
4.0	4	43	103889	210	8.5	24.0	0.400	0.269
6.0	4	56	103890	175	9.0	26.5	0.500	0.335
10.0	4	78	103891	300	10.5	33.0	0.760	0.510
16.0	4	104	103892	480	12.5	38.0	1.100	0.739
25.0	4	138	103893	750	14.0	44.5	1.580	1.061
35.0	4	171	100481	276	16.5	50.5	2.150	1.444
50.0	4	213	103894	396	19.0	59.5	2.960	1.988
70.0	4	263	103895	560	21.0	71.0	4.000	2.687

*These ampacities are a general guide to conductor size selections. They are not intended to supercede NEC or ICEA ampacity tables.

Cable Connector Assemblies

These connector assemblies include Neoprene glands. Field cut to match the cable or factory cut before shipment. Call factory for details.

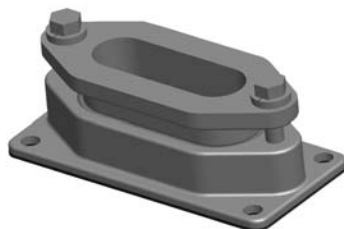

Size	Part No.	Wt. #
2 3/4" x 7/8"	26112	1.75
5 1/4" x 1 3/4"	26113	2.0
4 1/2" x 2 3/4"	26114	4 3/4

For the most current and up to date information visit our website at:

www.conductix.us

Stretched Wire Festoon Kits

Stretched Wire Rope Festoon Systems are well suited for light duty applications where an intermediate support structure is not available. Economical and dependable, stretched wire rope systems provide electrification to small cranes, moving hoists, and jib cranes.

LOAD: 10 LBS (1 WHEEL) MAX. SPEED: 200 FPM MAX.
LOAD: 20 LBS (2 WHEEL) MAX. SPEED: 200 FPM MAX.

For Flat Cable:

Kit Part Number		Max. Span (In Feet)	No. of Trolleys in Kit
Max. Cable Width			
Single Wheel 3/4" Max.	Double Wheel 1-3/4" Max.		
24862	24867	20	3
24863	24868	40	6
24864	24869	60	9
24865	24870	80	13
24866	24871	100	17

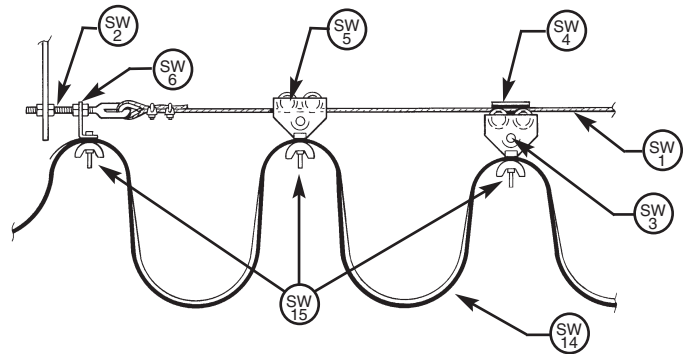

Kits include all components listed below:

Catalog #	Component	Catalog #	Component
SW 1 22950	Nylon Coated Wire Rope, 1/4" Dia.	SW 6 22836	Anchor Bracket
SW 2 23288	Hardware Kit	SW 14 22834	Flat Cable Saddle < 3/4" (20mm) wide
SW 3 39618	Tow Bar	SW 15 22835	Flat Cable Clamp
SW 4 22828	Tow Trolley (2 wheel)		
SW 5 22825	Trolley (1 wheel)		
	22826		
	Trolley (2 wheel)		

For Hose & Round Cable:

Kit Part Number						Max. Span (In Feet)	No. of Trolleys in Kit
Cable / Hose O.D.							
3/16" - 3/8" Max.		3/8" - 9/16" Max.		9/16" - 3/4" Max.			
*1 Wheel	2 Wheel	*1 Wheel	2 Wheel	*1 Wheel	2 Wheel		
24872	24887	24877	24892	24882	24897	20	3
24873	24888	24878	24893	24883	24898	40	6
24874	24889	24879	24894	24884	24899	60	9
24875	24890	24880	24895	24885	24900	80	13
24876	24891	24881	24896	24886	24901	100	17

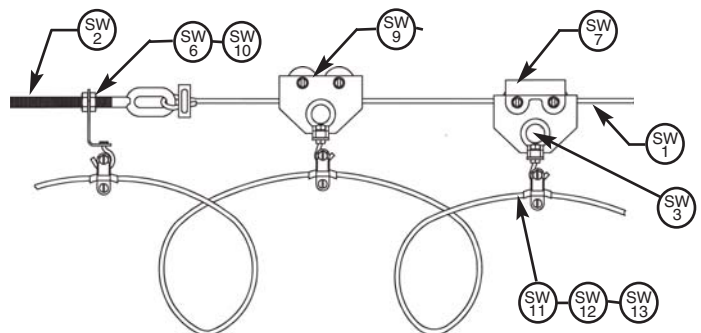

Catalog #	Component	Catalog #	Component
SW 1 22950	Nylon Coated Wire Rope, 1/4" Dia.	SW 9 22827	Trolley (2 wheel) shown
SW 2 23288	Hardware Kit	SW 10 25689	Adapter
SW 3 39618	Tow Bar	SW 11 22831	Cable Clip (3/16" to 3/8")
SW 6 22836	Anchor Bracket	SW 12 22832	Cable Clip (3/8" to 9/16")
SW 7 22829	Tow Trolley (2 wheel)	SW 13 22833	Cable Clip (9/16" to 3/4")
SW 8 22825	*Trolley (1 wheel) not shown		

Standard Duty C-Track Festoon Systems

Typical C-Track Festoon Systems (*Power & Control*) For Overhead Crane Installation

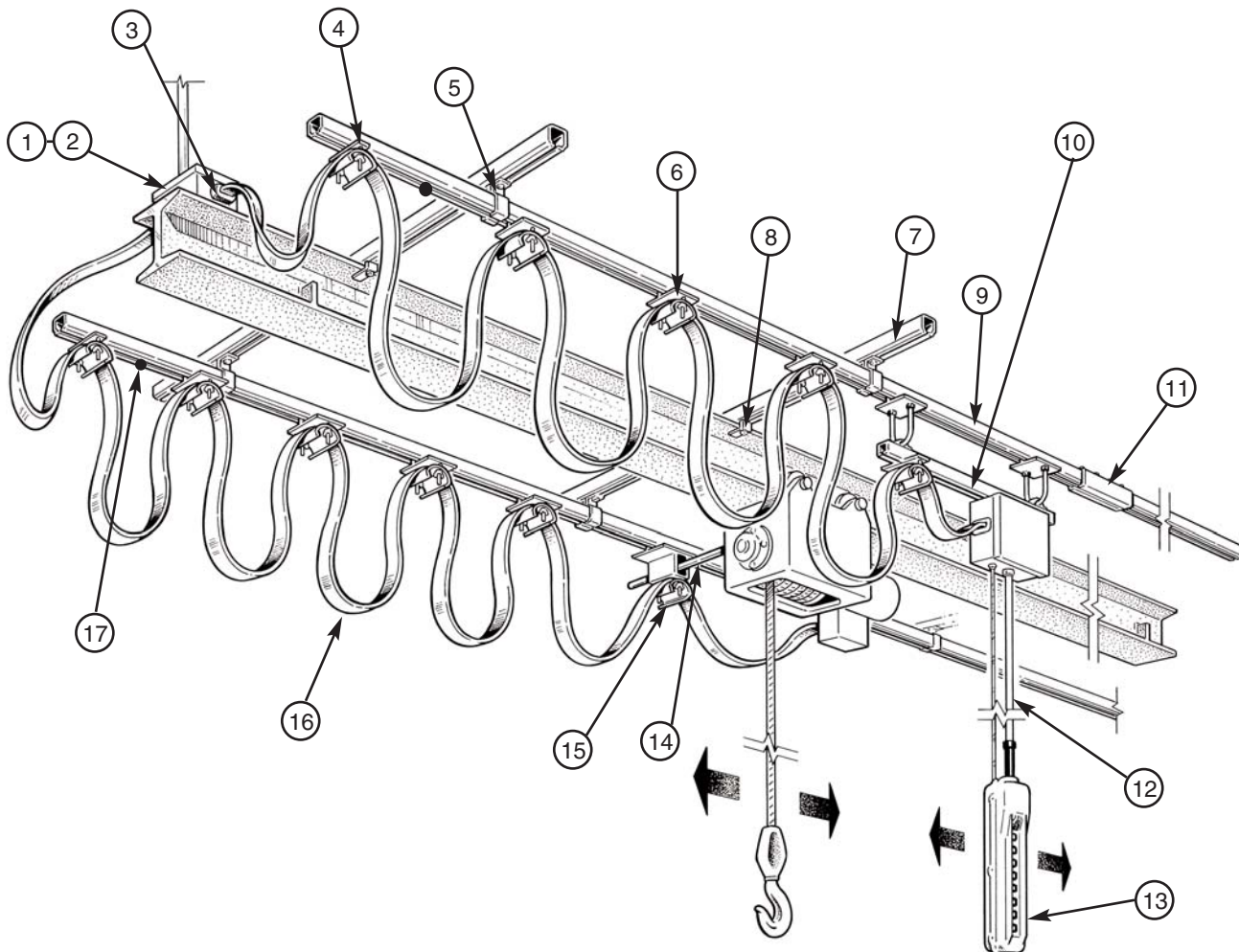

- | | |
|--|---|
| ① Fixed End Junction Box | ⑩ Control Unit Trolley with J-Box;
or Quick Disconnect Control Unit
Trolley (not shown) |
| ② Terminal Strips (<i>inside junction box</i>) | ⑪ Track Joint Assembly |
| ③ Cable Connectors | ⑫ Pendant Cable |
| ④ End Clamp | ⑬ Push-Button Pendant Station |
| ⑤ Track Hanger Clamp Assembly | ⑭ Tow Arm |
| ⑥ Intermediate Trolley | ⑮ Tow Trolley |
| ⑦ Cross Arm Support Channels | ⑯ Flat PVC Cable |
| ⑧ Beam Clamp (for cross arm
support channels) | ⑰ End Stop |
| ⑨ C-Track Channel | |

C-Track Festoon Mounting Arrangements

To choose festoon components for overhead crane systems, consideration must be given to mounting arrangement. Shown below are four typical arrangements. For all versions, the types and lengths of cable will be needed (track length + 10%, plus hook-up lengths), along with the type of control trolley (J-Box or Quick-Disconnect), and Push Button Pendant, if needed (and type and length of Pendant Cable - see Pendant & Radio Catalog).

Box Girder Style Crane - Control and Power Festoon on Opposite Sides

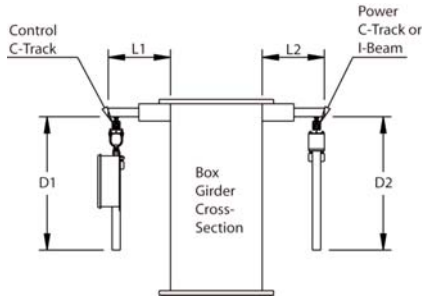

To quote this layout, we will need the information above plus:

- Lengths L1 and L2, if **CONDUCTIX** is to supply the cross beam support channels
- Max. loop depth D1 from top of C-Track, and D2 from top of C-Track (or bottom of I-Beam, if I-Beam is used instead of C-Track)
- Beam size (if I-Beam is used for power festoon)

I-Beam Style Crane - Control and Power Festoon on Opposite Sides

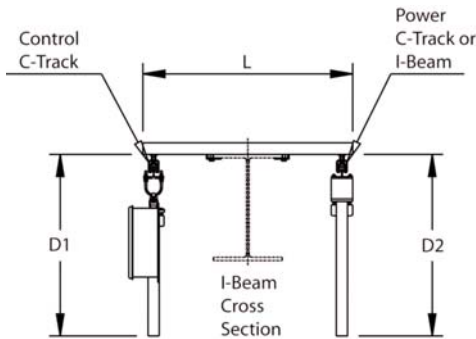

To quote this layout, we will need the information above plus:

- Length L, if **CONDUCTIX** is to supply the cross beam support channels
- Max. loop depth D1 from top of C-Track and D2 from top of C-Track (or bottom of I-Beam, if I-Beam is used instead of C-Track)
- Beam size (if I-Beam is used for power festoon)
- The size and type of the main beam cap, if one is present

I-Beam Style Crane - Control and Power Festoon on Same Side

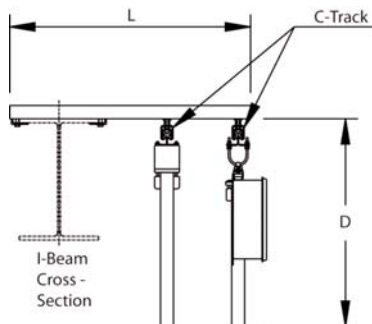

To quote this layout, we will need the information above plus:

- Length L, if **CONDUCTIX** is to supply the cross beam support channels
- Max. loop depth D from top of C-Track
- The size and type of the main beam cap, if one is present

I-Beam Style Crane - Control and Power Festoon on Same Side, Welded Cross Support

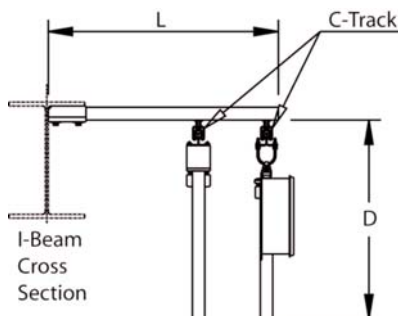

To quote this layout, we will need the information above plus:

- Length L, if **CONDUCTIX** is to supply the cross beam support channels



Note that cross beam support interfaces with customer supplied bracket welded to underside of main beam

- Max. loop depth D from top of C-Track

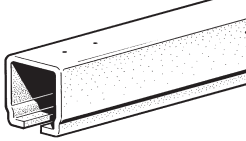
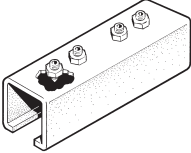
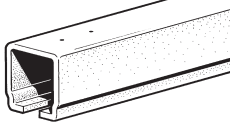
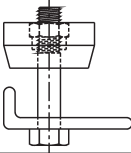
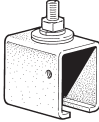
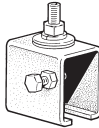
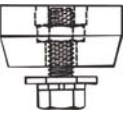

For the most current and up to date information visit our website at:

www.conductix.us

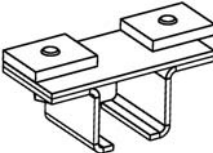
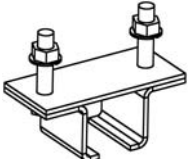
Standard Duty C-Track System Components

See Pg. 10 for system illustration	Galvanized Part No.	Stainless Part No.	Wt. #	Description
	33690 22209 21909 <small>Call for curves</small>	39996 27725 27724	5 10 20	14 Gauge C-Track Channel 5 ft. Section 10 ft. Section 20 ft. Section
	21954 31856	27726 32059	.75 .75	Track Joint Assembly One required for each track section per run, less one. Joint clamp for secure attachment and proper alignment of track sections. Includes four bolts, lock washers, and nuts. Optional Welded Joint Assembly for joining track section.
	36678_ 36679_	N/A N/A	2.0 / ft. 1.0 / ft.	Cross Arm Support Channel 12 gauge (ordered in 6" increments from 12" to 48") 14 gauge (ordered in 6" increments from 12" to 48")
	22264	N/A	.38	Aluminum Beam Clamp for Cross Arm Support Channels Two required for each cross arm support channel
	28510 35707 22005	28741 N/A N/A	.40 .51 .81	Track Hanger Clamp Assembly One required for each cross arm support bracket for each track run. 5' spacing. Designed to be mounted on angle iron brackets with one mounting hole. For mounting track to Cross Arm Support Bracket. Includes all required hardware. <i>(Not Shown)</i> Low profile track hanger assembly for mounting track to cross arm support <i>(Not Shown)</i>
	28511 35706	28742 N/A	.40 .40	Anchor Clamp - holds channel in place One required per track run - includes hardware. For use with C-Channel For use with Cross Arm Support Channel <i>(not shown)</i>
	23381	27727	.20	End Stop One required for power system, two required for control systems with control trolley.
	38841	N/A	.28	Track Support Bracket w/o fastener Allows the removal of single section of C-Track
	38653	N/A	.47	Track Support Bracket With fasteners to mount to Cross Arm Support
	38654	N/A	.40	Track Support Bracket With mounting fasteners

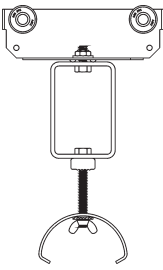
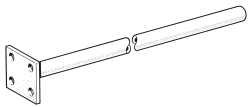
Standard Duty C-Track System Components

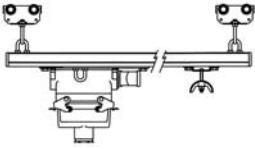
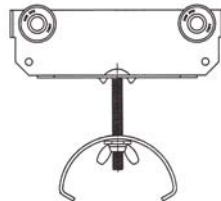
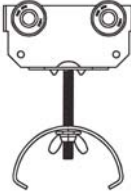
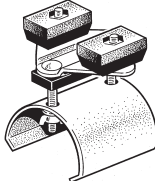
See Pg. 10 for system illustration	Galvanized Part No.	Stainless Part No.	Wt. #	Description
	22168		1.12	Tow Trolley One required for each piece of moving equipment to be electrified. Plated steel trolley with 2.75" Dia. saddle with cut out for tow bar.
	28614		.70	Plastic trolley with 2" Dia. plastic saddle with cut out for tow bar.
		39274	1.12	Stainless steel body and saddle with stainless steel sealed wheels and hardware.
	39618		1.2	Tow Bar One required for each tow trolley. For mounting on moving equipment 16" long.
	22203B		2.75	Control Unit Trolley for J-Box⁺ Two trolleys and one steel saddle mounted on bracket plus fittings to attach control box. (<i>Control box not included.</i>)
		32166	3.0	Same as 22203B except with stainless steel body and saddle with stainless steel sealed wheels and hardware.
See Page 28.	-	-	-	Junction Boxes and Terminals
	2366 (16 Pin)		5.28	Control Unit Trolley with Quick Disconnect Lead trolley in control festoon system. Manually pulled with push-button pendant attached to drop cable. Drop cable is then wired into lower half of "quick disconnect". Flat festoon cable is wired into upper half of "quick disconnect". Zinc plated steel trolleys and hardware.
	2367 (24 Pin)		5.59	Electrical Ratings: 16A Max. 600 Volts AC. See Pg. 25 for more details.
	21941			Intermediate Trolley - 5" 5-inch trolley with 4 steel shielded ball bearing wheels. 2.75" dia. steel saddle and hardware. Stainless steel body and saddle with stainless steel sealed wheels and hardware.
	21991		.70	Intermediate Trolley - 3" 3-inch steel trolley with 4 shielded steel ball bearing wheels, 2.75" dia. steel saddle and hardware.
	28615		.40	3-inch plastic trolley with 4 shielded steel ball bearing wheels, 2" dia. plastic saddle. (<i>Not Shown</i>)
		39227	.70	Stainless steel body and saddle with stainless steel sealed wheels and hardware.
	21957		.56	End Clamp One required for each track run at storage end of track 2.75" dia. steel saddle with clamp and hardware to secure cable.
	28616		.42	2" dia. plastic saddle with clamp to secure cable.
		39226	.56	Stainless steel body and saddle with stainless steel hardware.

Heavy-Duty C-Track Systems

Typical Heavy Duty C-Track Festoon Systems (Power & Control) For Overhead Crane Installation

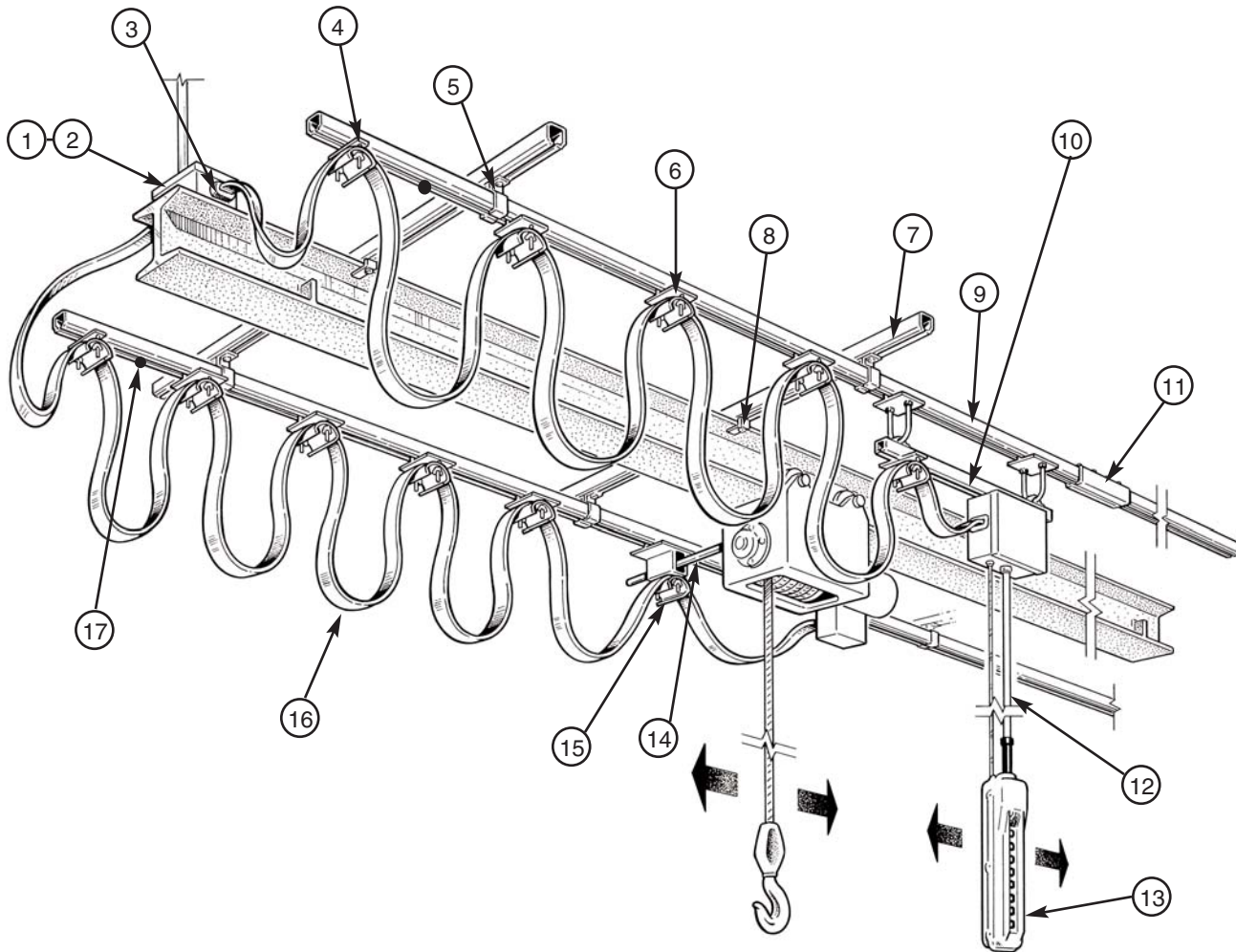

- | | |
|--|---|
| ① Fixed End Junction Box | ⑩ Control Unit Trolley with J-Box;
or Quick Disconnect Control Unit
Trolley (not shown) |
| ② Terminal Strips (<i>inside junction box</i>) | ⑪ Track Joint Assembly |
| ③ Cable Connectors | ⑫ Pendant Cable |
| ④ End Clamp | ⑬ Push-Button Pendant Station |
| ⑤ Track Hanger Clamp Assembly | ⑭ Tow Arm |
| ⑥ Intermediate Trolley | ⑮ Tow Trolley |
| ⑦ Cross Arm Support Channels | ⑯ Flat PVC Cable |
| ⑧ Beam Clamp (for cross arm
support channels) | ⑰ End Stop |
| ⑨ Heavy Duty C-Track Channel | |

Heavy-Duty C-Track System Components

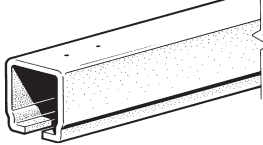
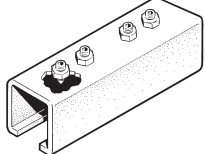
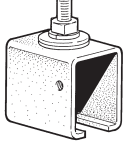
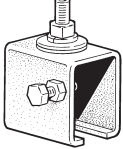
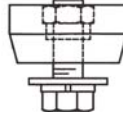
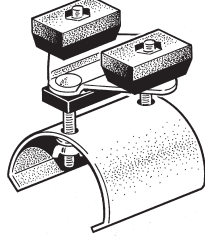
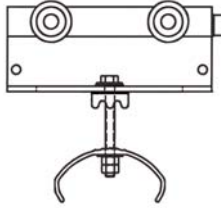
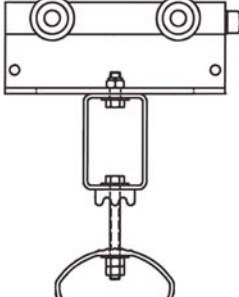
See Pg. 14 for system illustration	Part No.	Wt. #	Description
	<p>22302J 22210 21805</p> <p>Curved sections not available</p>	<p>10.0 20.0 40.0</p>	<p>12 Gauge C-Track</p> <p>5 ft. Section See Pg. 12 10 ft. Section P/N: 36678 20 ft. Section For Cross Arm Support Channel</p>
	<p>21806</p>	<p>1.08</p>	<p>Track Joint Assembly One required for each track section per run less one.</p> <p>Joint clamp for secure attachment and proper alignment of track sections. Includes four bolts, lock washers and nuts.</p>
	<p>28512</p>	<p>.45</p>	<p>Track Hanger Clamp Assembly One required for each angle iron bracket for each track run. 10' spacing.</p> <p>Designed to be mounted on angle iron brackets with one mounting hole.</p>
	<p>28513</p>	<p>.45</p>	<p>Anchor Clamp One required per track run.</p> <p>Designed to hold track in place.</p>
	<p>28508</p>	<p>.20</p>	<p>End Stop One required for each track run at storage end of track.</p>
	<p>21932</p>	<p>1.63</p>	<p>7.5" End Clamp One required for each track run at storage end of track.</p> <p>Aluminum saddle 4" dia. with clamp and hardware to secure cable 5 1/4" wide.</p>
	<p>21802</p>	<p>3.0</p>	<p>7.5" Cable Trolley</p> <p>Load Rating: 80 lbs. per Trolley</p> <p>High strength aluminum body with 4" dia. aluminum saddle. Trolley bumpers.</p>
	<p>22169</p>	<p>4.75</p>	<p>7.5" Tow Trolley</p> <p>Load Rating: 80 lbs. per Trolley</p> <p>One required for each piece of moving equipment to be electrified.</p> <p>Trolley and aluminum saddle 4" dia. with cut out for tow bar.</p>

Heavy-Duty C-Track System Components

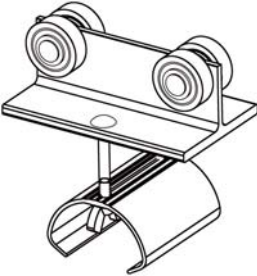
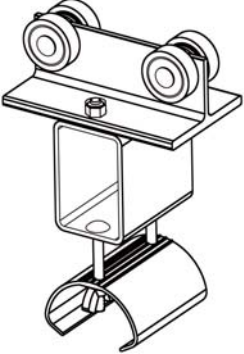
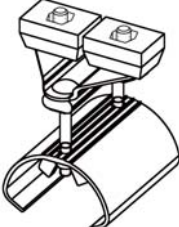
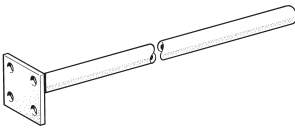
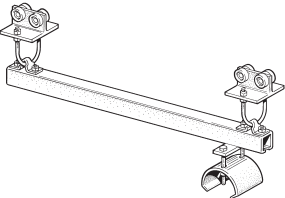
See Pg. 14 for system illustration	Part No.	Wt. #	Description
	38641	1.48	5" Cable Trolley High strength aluminum body and saddle with zinc plated hardware.
	38646	1.90	5" Tow Trolley High strength aluminum body and saddle with zinc plated hardware.
	24767	.50	5" End Clamp Aluminum saddle with clamp & hardware to secure cable.
	39617C	2.63	Tow Bar One required for each tow trolley. For mounting on moving equipment 24" long.
	22350	12.5	Control Box Trolley Two trolleys and one aluminum saddle 4" dia. mounted on bracket plus, fittings to attach control box. <i>(junction box sold separately below)</i>
See Pg. 28			Junction Boxes and Terminal Strips

Standard Duty Square Bar Components

Festoon systems that run on square bar are ideal for very dusty environments. The bar, oriented in a diamond configuration, does not collect dust. **Load:** 45lb. per trolley **Speed:** 250 fpm. max.

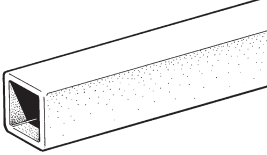
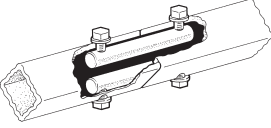
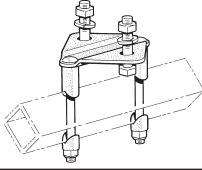
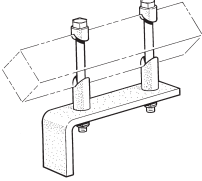
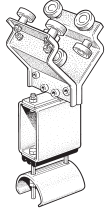
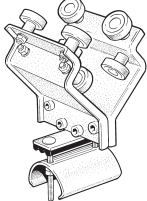
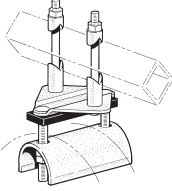
	Standard Part No.	Stainless Part No.	Wt. #	Description
	24525	27843	28.0	Track (Square Bar) 20 ft. Section, Hot-Rolled Steel Track
	34601 Call for Curves		28.0	20 ft. Section, Stainless Steel Track
			28.0	20 ft. Section, Galvanized Steel Track
	25681	27845	.25	Track Joint Track joint for secure attachment and proper alignment of track sections.
	25598	27846	.50	Track Hanger Designed to be mounted on angle iron bracket. 5' spacing. Typical, 2.5' spacing in storage area. NOTE: Use Drill Fixture for Drilling Holes. Part #: 25726
	25596	27847	.75	End Stop Designed to be located between end clamp and intermediate trolley.
	25594	28621	3.0	Tow Trolley Load rating 45 lbs. max. One required per system. 4" long body with cut out for Tow Bar.
See Pg. 28				Junction Boxes and Terminal Strips
	25593	28622	2.5	Cable Trolley Trolley load rating 45 lbs. max. 4" long body with 2.75" dia. aluminum saddle.
	25595	28548	1.50	End Clamp One required per system at storage end of track.

Heavy Duty Square Bar Components

The Heavy Duty Square Bar system is similar to the standard system, but with a heavier bar.

Load: 150 lbs. per Trolley. **Speed:** 250 fpm. max.

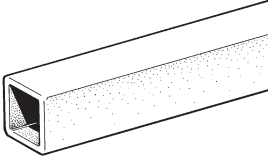
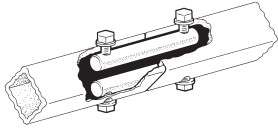
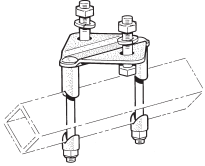
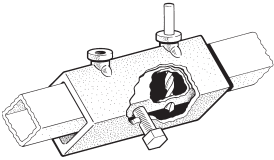
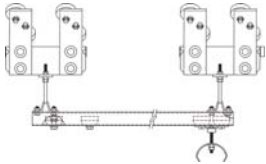
	Standard Part No.	Stainless Part No.	Wt. #	Description
	24526	27763	46.0	Track (<i>Heavy Square Bar</i>) 20 ft. Section, Hot Rolled Steel Track
	34603		46.0	20 ft. Section, Stainless Steel Track 1.50" Sq.
			46.0	20 ft. Section, Galvanized Steel Track
	25683	27664	.50	Track Joint Track joint for secure attachment and proper alignment of track sections.
	25667	27671	1.50	Track Hanger Designed to be mounted on angle iron bracket. 5' spacing. Typical, 2.5' spacing in storage area.
	25726	25726	2.0	Drill Fixture Used for drilling holes at proper locations for attachment of hangers, end clamps and end stops.
	25670	Special Unit. Available upon request.	26.0	Control Box Trolley Two trolleys and one aluminum saddle 4" dia. mounted on bracket plus fittings to attach control box. (<i>Control box not included</i>)
See Pg. 28				Junction Boxes and Terminal Strips

Curved Square Bar Systems

Curved festoon systems may be required for electrification and/or control of curved monorails and machines that travel in a circular motion. Also, some systems may require more storage space than available.

Additional storage space may also be gained by curving the festoon track 90° to the crane rail.

Consult **CONDUCTIX** for details on curved systems and other solutions for your festoon application.

Heavy Duty Square Bar Trolleys for Flat Cable

Heavy Duty Square Bar Trolleys feature all-steel body construction with aluminum cable saddle. The trolleys are suitable for indoor and outdoor applications for flat cable. Standard wheels are steel with sealed ball bearings.

Trolley Body includes Running Gear. SS = "stainless steel"

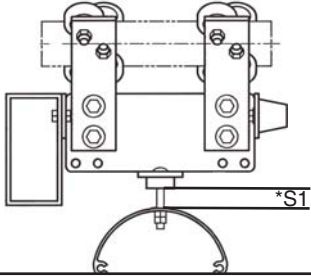
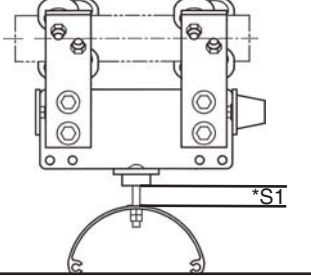
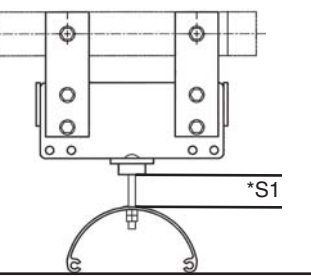
Load: 150 lbs max. Speed: 250 fpm max.	Tow Trolley	Cable Trolley	End Clamp
			
Body	Zinc plated steel, or SS	Zinc plated steel, or SS	Zinc plated steel, or SS
Saddle	Aluminum	Aluminum	Aluminum
Main Rollers*	1.77" dia.	1.77" dia.	n/a
Hardware	Zinc plated steel, or SS	Zinc plated steel, or SS	Zinc plated steel, or SS
Cable Pad	Neoprene Rubber	Neoprene Rubber	Neoprene Rubber
No. Required per System	One- tow trolley is supplied with towing box for tow bar. Anti-lift rollers are req'd.	One per cable loop. Anti-lift rollers are optional	One-plus appropriate mounting clamp as determined by factory.

*Spark resistant bronze rollers are available for hazardous locations - consult the factory

	Saddle		Unit Length	Cable Window		Zinc Plated Part No.	Stainless Steel Part No.	Wt. #
	Dia.	Width		Width (in.)	*S1 Hgt. (In.)			
Tow Trolley	4	5 1/4	11 1/8	3.9	2.0	45400	45413	13.5
Cable Trolley	4	5 1/4	8 5/8	3.9	2.0	45426	45440	11.5
End Trolley	4	5 1/4	7 3/8	3.9	2.0	45453	45446	8.5
Tow Trolley	4	6	11 1/8	6.7	2.0	45400B	45413B	13.5
Cable Trolley	4	8	8 5/8	6.7	2.0	45426B	45440B	11.5
End Trolley	4	8	7 3/8	6.7	2.0	45453B	45446B	8.5
Tow Trolley	6	5 1/4	12 5/8	3.9	2.0	45406	45419	13.5
Cable Trolley	6	5 1/4	10 1/8	3.9	2.0	45432	45446	11.5
End Trolley	6	5 1/4	8 7/8	3.9	2.0	45459	45472	8.5
Tow Trolley	6	8	12 5/8	6.7	2.0	45406B	45419B	13.5
Cable Trolley	6	8	10 1/8	6.7	2.0	45432B	45446B	11.5
End Trolley	6	8	8 7/8	6.7	2.0	45459B	45472B	8.5
Tow Trolley	8	5 1/4	11 1/8	3.9	2.0	45410	45423	13.5
Cable Trolley	8	5 1/4	8 5/8	3.9	2.0	45436	45450	11.5
End Trolley	8	5 1/4	7 3/8	3.9	2.0	45463	45476	8.5
Tow Trolley	8	8	15 1/8	6.7	2.0	45410B	45423B	13.5
Cable Trolley	8	8	12 5/8	6.7	2.0	45436B	45450B	11.5
End Trolley	8	8	11 3/8	6.7	2.0	45463B	45476B	8.5

*Taller cable window heights are available - contact the factory

Heavy Duty Square Bar Trolleys for Round Cable

Heavy Duty Square Bar Trolleys feature all-steel body construction with aluminum cable saddle. The trolleys are suitable for indoor and outdoor applications for round cable. Standard wheels are steel with sealed ball bearings.

Trolley Body includes Running Gear. SS = "stainless steel"

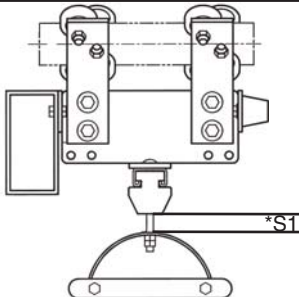
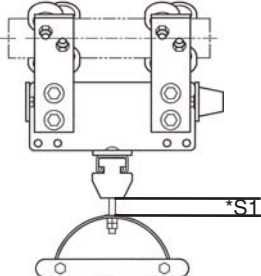
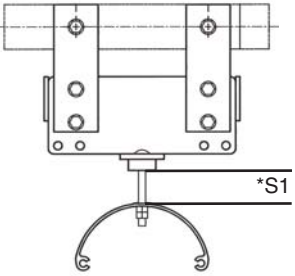
Load: 150 lbs max. Speed: 250 fpm max.	Tow Trolley	Cable Trolley	End Clamp
			
Body	Zinc plated steel, or SS	Zinc plated steel, or SS	Zinc plated steel, or SS
Saddle	Aluminum	Aluminum	Aluminum
Main Rollers*	1.77" dia.	1.77" dia.	n/a
Hardware	Zinc plated steel, or SS	Zinc plated steel, or SS	Zinc plated steel, or SS
Cable Pad	Neoprene rubber	Neoprene rubber	Neoprene rubber
No. Required per System	One - tow trolley is supplied with towing box for tow bar. Anti-lift rollers are req'd.	One per cable loop. Anti-lift rollers are optional	One - plus appropriate mounting clamp as determined by factory

*Spark resistant bronze rollers are available for hazardous locations - consult the factory

	Saddle		Unit Length	Cable Window		Zinc Plated Part No.	Stainless Steel Part No.	Wt. #
	Dia.	Width		Width (in.)	*S1 Hgt. (in.)			
Tow Trolley	4	5 1/4	11 1/8	3.9	0.4	45403	45416	14.0
Cable Trolley	4	5 1/4	8 5/8	3.9	0.4	45429	45443	12.0
End Trolley	4	5 1/4	7 3/8	3.9	0.4	45456	45469	9.0
Tow Trolley	4	8	11 1/8	6.7	0.4	45403B	45416B	14.0
Cable Trolley	4	8	8 5/8	6.7	0.4	45429B	45443B	12.0
End Trolley	4	8	7 3/8	6.7	0.4	45456B	45469B	9.0
Tow Trolley	6	5 1/4	12 5/8	3.9	0.6	45408	45421	14.0
Cable Trolley	6	5 1/4	10 1/8	3.9	0.6	45434	45448	12.0
End Trolley	6	5 1/4	8 7/8	3.9	0.6	45161	45474	9.0
Tow Trolley	6	8	12 5/8	6.7	0.6	45408B	45421B	14.0
Cable Trolley	6	8	10 1/8	6.7	0.6	45434B	45448B	12.0
End Trolley	6	8	8 7/8	6.7	0.6	45461B	45474B	9.0
Tow Trolley	8	5 1/4	11 1/8	3.9	0.8	45411	45424	14.0
Cable Trolley	8	5 1/4	8 5/8	3.9	0.8	45437	45451	12.0
End Trolley	8	5 1/4	7 3/8	3.9	0.8	45464	45477	9.0
Tow Trolley	8	8	15 1/8	6.7	0.8	45411B	45424B	14.0
Cable Trolley	8	8	12 5/8	6.7	0.8	45437B	45451B	12.0
End Trolley	8	8	11 3/8	6.7	0.8	45464B	45477B	9.0

*Taller cable window heights are available - contact the factory

For the most current and up to date information visit our website at:

www.conductix.us

Series 200 I Beam for Flat Cable

This I-Beam festoon system is ideal for slow speed operation at speeds up to but not exceeding 200 fpm with loads of up to 55lbs. The Series 200 "I" Beam System can be strategically used indoors where festoon cable systems are required to operate on an "I" Beam. These "I" Beam trolleys are sand cast aluminum with nylon wheels.

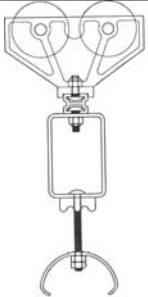
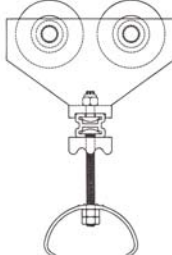
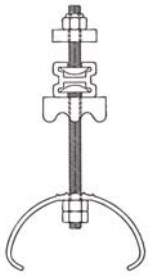
Load: 55 lbs max. Speed: 200 fpm max.	Tow Trolley	Cable Trolley	End Clamp
			
Nylon Wheels	24829	24830	24828
Nylon Wheels w/o Anti-Lift Rollers	24829B	24830B	24828B
Steel Wheels	28904	33530	24828
Steel Wheels w/o Anti-Lift Rollers	28904B	33530B	24828B
Weight in Pounds	2.75	2.0	.75
Description	One Tow Trolley required per system. Supplied with towing box for tow bar.	Standard construction consists of 5" long body, 2.75" Dia. x 4" wide saddle. Maximum load per trolley is 55 lbs.	One End Clamp required per system. Bolted to "I" Beam with (2) 1/4-20 x .25" mounting bolts.

Specifications & Dimensions

Body: Sand Cast Aluminum
Saddle: 2.75" Dia. Aluminum
Wheels: Nylon or Steel
Cable Pad: Neoprene Rubber

Load: 55 lbs. max. per trolley
Speed: 200 fpm. max.
Maximum "I" Beam Flange Width: 4.50"

Note: Stainless Steel axle and hardware is available. Call factory for details.

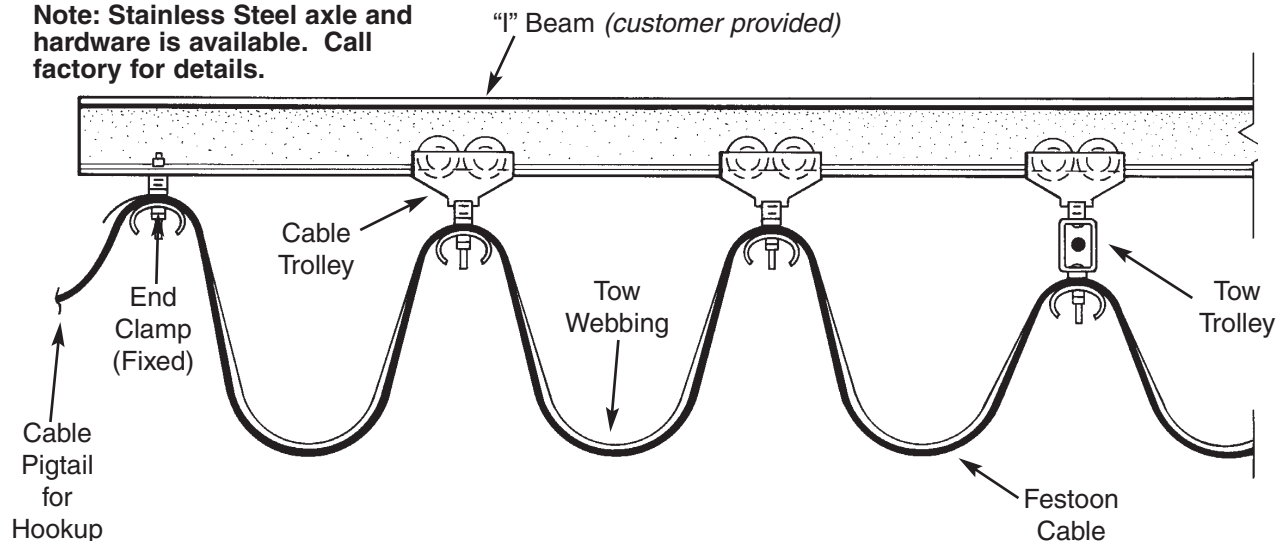

Series 225 I Beam for Flat Cable

The economical Series 225 "I" Beam Trolleys for flat cable are designed to run on S3 x 5.7#, S3 x 7.5# or S4 x 7.7# "I" beams only. The saddle is suspended from the trolley by a pivot mechanism which allows the cable package to sway during crane operation providing smoother operation. Lead trolleys are supplied with anti-lift rollers as standard.

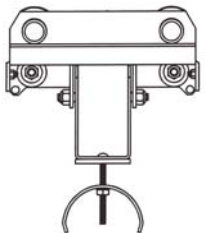
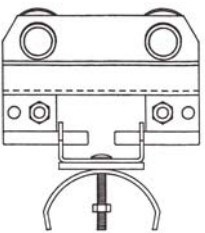
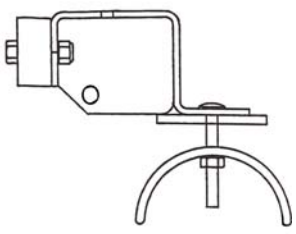
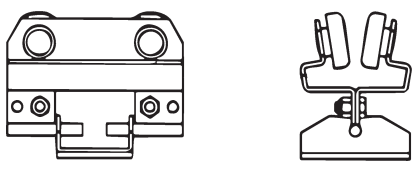
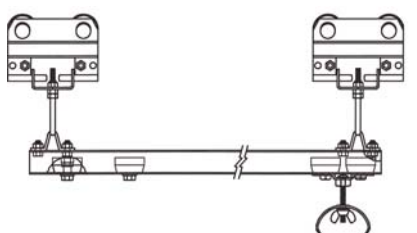
Load: 150 lbs. max. Speed: 225 fpm. max.	Part No.	Wt. #	Description
	34366	9.0	Tow Trolley One required per system. Complete with Anti-Lift Rollers positioned as Lead Trolley in system is equipped with cut out box for engagement of tow bar from mobile consumer. Length = 8.00"
	34364		Cable Trolley Standard construction consists of steel body, steel saddle. Maximum load per trolley is 150 lbs. Length = 5.50"
	34365	5.0	End Clamp One End Clamp required per system. Positioned at end of system and clamped to "I" Beam. Length = 7.77"
	34407	5.0	Single Control Trolley Single trolley suitable for mounting junction box. Length = 5.5"
	34925	13.0	Control Box Trolley Two trolleys and one steel saddle mounted on bracket plus fittings to attach control box. Junction box sold separately (See Page 16.) Length = 26.25"

Specifications

Body: Low Carbon Steel

Saddle: Low Carbon Steel

Finish: Zinc Plated w / yellow Dichromate Seal

Hardware: Zinc Plated

Rollers:

- Main - 1.68" Dia. Hardened Steel
- Anti-Lift - 1.19" Dia. Hardened Steel

Saddle Diameter: 3.4"

Cable Window: 2.38" wide x 1.00" high

Series 250 I Beam for Flat Cable

Series 250 "I" Beam Trolleys feature zinc plated or stainless steel body and hardware, aluminum saddles with Neoprene pads. These trolleys are suitable for indoor and outdoor applications for flat cable.

Note: Order Trolley Body and Running Gear Separately. SS = "stainless steel"

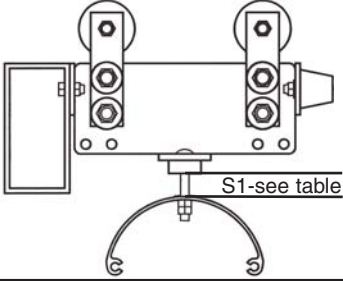
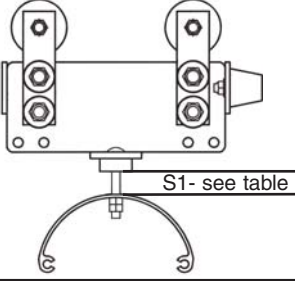
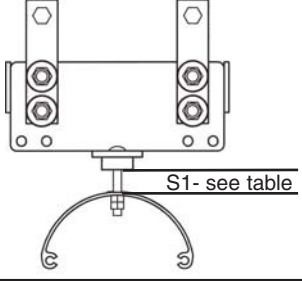
Load: 95 lbs max. Speed: 250 fpm max.	Tow Trolley	Cable Trolley	End Clamp
			
Main Rollers*	1.58" dia. steel flanged	1.58" dia. steel flanged	n/a
Anti-Lift Rollers (if ordered)	1.38" dia. steel	1.38" dia. steel	n/a
No. Required per System	One - tow trolley is supplied with towing box for tow bar. Anti-lift rollers are req'd.	One per cable loop. Anti-lift rollers are optional	One - plus approximate mounting clamp as determined by factory

*Spark resistant bronze rollers are available for hazardous locations - consult the factory

	Saddle		Unit Length	Cable Window		Zinc Plated Part No.	Stainless Steel Part No.	Wt. #
	Dia.	Width		Width (in.)	*S1 Hgt. (in.)			
Tow Trolley	4	5 1/4	11 1/8	3.9	2.0	45100	45113	14.5
Cable Trolley	4	5 1/4	8 5/8	3.9	2.0	45126	45140	10.0
End Trolley	4	5 1/4	7 3/8	3.9	2.0	45153	45166	8.0
Tow Trolley	4	8	11 1/8	6.7	2.0	45100B	45113B	14.5
Cable Trolley	4	8	8 5/8	6.7	2.0	45126B	45140B	10.0
End Trolley	4	8	7 3/8	6.7	2.0	45153B	45166B	8.0
Tow Trolley	6	5 1/4	12 5/8	3.9	2.0	45106	45119	14.5
Cable Trolley	6	5 1/4	10 1/8	3.9	2.0	45132	45146	10.0
End Trolley	6	5 1/4	8 7/8	3.9	2.0	45159	45172	8.0
Tow Trolley	6	8	12 5/8	6.7	2.0	45106B	45119B	14.5
Cable Trolley	6	8	10 1/8	6.7	2.0	45132B	45146B	10.0
End Trolley	6	8	8 7/8	6.7	2.0	45159B	45172B	8.0
Tow Trolley	8	5 1/4	11 1/8	3.9	2.0	45110	45123	14.5
Cable Trolley	8	5 1/4	8 5/8	3.9	2.0	45136	45150	10.0
End Trolley	8	5 1/4	7 3/8	3.9	2.0	45163	45176	8.0
Tow Trolley	8	8	15 1/8	6.7	2.0	45110B	45123B	14.5
Cable Trolley	8	8	12 5/8	6.7	2.0	45136B	45150B	10.0
End Trolley	8	8	11 3/8	6.7	2.0	45163B	45176B	8.0

*Taller cable window heights are available - contact the factory

Running Gear for W-Beams

Without Anti-Lift Rollers: **45197*** (SS: **45202***)

With Anti-Lift Rollers: **45198*** (SS: **Consult Factory**)

Beam	Code	Beam	Code
W4 x 13	A	W6 x 9	D
W5 x 16	B	W6 x 12	E
W5 x 19	C	W8 x 10	K

Running Gear for S-Beams

Without Anti-Lift Rollers: **45187*** (SS: **45192***)

With Anti-Lift Rollers: **45188*** (SS: **45194***)

Beam	Code	Beam	Code
S4 x 7.7	C	S6 x 12.5	G
S4 x 9.5	D	S6 x 17.25	H
S5 x 10.0	E	S7 x 15.3	J

* Insert Code Letter to indicate beam size. For other beam sizes consult factory.

For the most current and up to date information visit our website at:

www.conductix.us

Series 250 I Beam for Round Cable

Series 250 "I" Beam Trolleys feature zinc plated or stainless steel body and hardware, aluminum saddles with Neoprene pads. These trolleys are suitable for indoor and outdoor applications for flat cable.

Note: Order Trolley Body and Running Gear Separately. SS = "stainless steel"

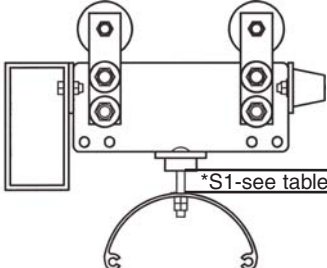
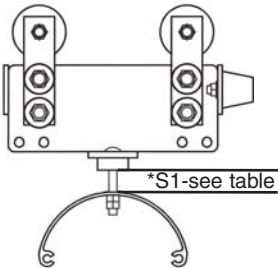
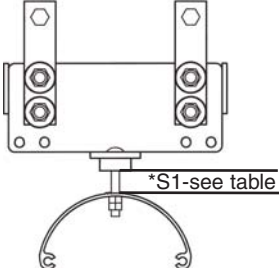
Load: 95 lbs max. Speed: 250 fpm max.	Tow Trolley	Cable Trolley	End Clamp
			
	*S1-see table	*S1-see table	*S1-see table
Main Rollers*	1.58" dia. steel flanged	1.58" dia. steel flanged	n/a
Anti-Lift Rollers (if ordered)	1.38" dia. steel	1.38" dia. steel	n/a
No. Required per System	One - tow trolley is supplied with towing box for tow bar. Anti-lift rollers are req'd.	One per cable loop. Anti-lift rollers are optional	One - plus appropriate mounting clamp as determined by factory

*Spark resistant bronze rollers are available for hazardous locations - consult the factory

	Saddle		Unit Length	Cable Window		Zinc Plated Part No.	Stainless Steel Part No.	Wt. #
	Dia.	Width		Width (in.)	*S1 Hgt. (in.)*			
Tow Trolley	4	5 1/4	11 1/8	3.9	0.4	45103	45116	15.0
Cable Trolley	4	5 1/4	8 5/8	3.9	0.4	45129	45143	10.5
End Trolley	4	5 1/4	7 3/8	3.9	0.4	45156	45169	8.5
Tow Trolley	4	8	11 1/8	6.7	0.4	45103B	45116B	15.0
Cable Trolley	4	8	8 5/8	6.7	0.4	45129B	45143B	10.5
End Trolley	4	8	7 3/8	6.7	0.4	45156B	45169B	8.5
Tow Trolley	6	5 1/4	12 5/8	3.9	0.6	45108	45119	15.0
Cable Trolley	6	5 1/4	10 1/8	3.9	0.6	45134	45146	10.5
End Trolley	6	5 1/4	8 7/8	3.9	0.6	45161	45172	8.5
Tow Trolley	6	8	12 5/8	6.7	0.6	45108B	45119B	15.0
Cable Trolley	6	8	10 1/8	6.7	0.6	45134B	45146B	10.5
End Trolley	6	8	8 7/8	6.7	0.6	45161B	45172B	8.5
Tow Trolley	8	5 1/4	11 1/8	3.9	0.8	45111	45124	15.0
Cable Trolley	8	5 1/4	8 5/8	3.9	0.8	45137	45151	10.5
End Trolley	8	5 1/4	7 3/8	3.9	0.8	45164	45177	8.5
Tow Trolley	8	8	15 1/8	6.7	0.8	45111B	45124B	15.0
Cable Trolley	8	8	12 5/8	6.7	0.8	45137B	45151B	10.5
End Trolley	8	8	11 3/8	6.7	0.8	45164B	45177B	8.5

*Taller cable window heights are available - contact the factory

Running Gear for W-Beams

Without Anti-Lift Rollers: **45197*** (SS: **45202***)

With Anti-Lift Rollers: **45198*** (SS: **Consult Factory**)

Beam	Code	Beam	Code
W4 x 13	A	W6 x 9	D
W5 x 16	B	W6 x 12	E
W5 x 19	C	W8 x 10	K

Running Gear for S-Beams

Without Anti-Lift Rollers: **45187*** (SS: **45192***)

With Anti-Lift Rollers: **45188*** (SS: **45194***)

Beam	Code	Beam	Code
S4 x 7.7	C	S6 x 12.5	G
S4 x 9.5	D	S6 x 17.25	H
S5 x 10.0	E	S7 x 15.3	J

* Insert Code Letter to indicate beam size. For other beam sizes consult factory.

For the most current and up to date information visit our website at:

www.conductix.us

Series 350 I Beam for Flat Cable

Series 350 "I" Beam Trolleys feature zinc plated or stainless steel bodies and hardware, aluminum saddles with Neoprene Pads. 350 Trolleys are suitable for a wide range of demanding applications. The trolleys are suitable for indoor and outdoor applications for flat cable.

Note: Order Trolley Body and Running Gear Separately. SS = "stainless steel"

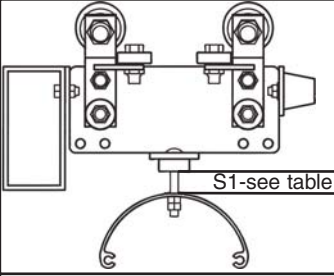
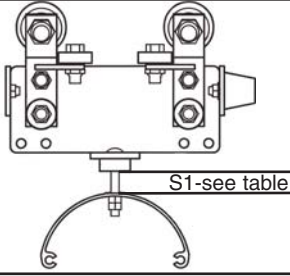
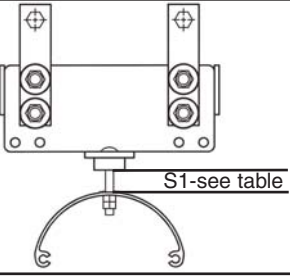
Load: 175 lbs max. Speed: 350 fpm max.	Tow Trolley	Cable Trolley	End Clamp
			
	S1-see table	S1-see table	S1-see table
Main Rollers*	2.0" dia. steel	2.0" dia. steel	n/a
Anti-Lift Rollers	1.38" dia. steel	1.38" dia. steel	n/a
No. Required per System	One - tow trolley is supplied with towing box for tow bar. Anti-lift rollers are req'd.	One cable per loop. Anti-lift rollers are optional	One - plus appropriate mounting clamp as determined by factory

*Spark resistant bronze rollers are available for hazardous locations - consult the factory

	Saddle		Unit Length	Cable Window		Zinc Plated Part No.	Stainless Steel Part No.	Wt. #
	Dia.	Width		Width (in.)	S1 Hgt. (in.)*			
Tow Trolley	4	5 1/4	11 1/8	3.9	2.0	45100	45113	16.5
Cable Trolley	4	5 1/4	8 5/8	3.9	2.0	45126	45140	12.0
End Trolley	4	5 1/4	7 3/8	3.9	2.0	45153	45166	10.0
Tow Trolley	4	8	11 1/8	6.7	2.0	45100B	45113B	16.5
Cable Trolley	4	8	8 5/8	6.7	2.0	45126B	45140B	12.0
End Trolley	4	8	7 3/8	6.7	2.0	45153B	45166B	10.0
Tow Trolley	6	5 1/4	12 5/8	3.9	2.0	45106	45119	16.5
Cable Trolley	6	5 1/4	10 1/8	3.9	2.0	45132	45146	12.0
End Trolley	6	5 1/4	8 7/8	3.9	2.0	45159	45172	10.0
Tow Trolley	6	8	12 5/8	6.7	2.0	45106B	45119B	16.5
Cable Trolley	6	8	10 1/8	6.7	2.0	45132B	45146B	12.0
End Trolley	6	8	8 7/8	6.7	2.0	45159B	45172B	10.0
Tow Trolley	8	5 1/4	11 1/8	3.9	2.0	45110	45123	16.5
Cable Trolley	8	5 1/4	8 5/8	3.9	2.0	45136	45150	12.0
End Trolley	8	5 1/4	7 3/8	3.9	2.0	45163	45176	10.0
Tow Trolley	8	8	15 1/8	6.7	2.0	45110B	45123B	16.5
Cable Trolley	8	8	12 5/8	6.7	2.0	45136B	45150B	12.0
End Trolley	8	8	11 3/8	6.7	2.0	45163B	45176B	10.0

Running Gear for W-Beams

Without Anti-Lift Rollers: **45195*** (SS: **45202***)

With Anti-Lift Rollers: **45196*** (SS: **Consult Factory**)

Beam	Code	Beam	Code
W4 x 13	A	W6 x 9	D
W5 x 16	B	W6 x 12	E
W5 x 19	C	W8 x 10	K

Running Gear for S-Beams

Without Anti-Lift Rollers: **45185*** (SS: **45190***)

With Anti-Lift Rollers: **45186*** (SS: **44853***)

Beam	Code	Beam	Code
S4 x 7.7	C	S6 x 12.5	G
S4 x 9.5	D	S6 x 17.25	H
S5 x 10.0	E	S7 x 15.3	J

* Insert Code Letter to indicate beam size. For other beam sizes consult factory.

For the most current and up to date information visit our website at:

www.conductix.us

Series 350 I Beam for Round Cable

Series 350 "I" Beam Trolleys feature zinc plated or stainless steel bodies and hardware, aluminum saddles with Neoprene Pads. 350 Trolleys are suitable for a wide range of demanding applications, such as large cranes and machinery in steel mills and aluminum smelters. The trolleys are suitable for indoor and outdoor applications for round cable.

Note: Order Trolley Body and Running Gear Separately. SS = "stainless steel"

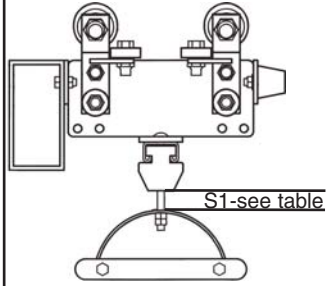
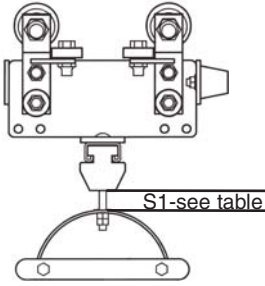
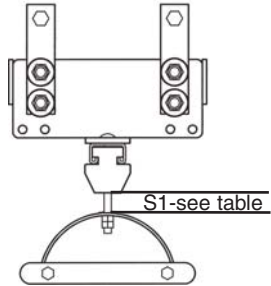
Load: 175 lbs max. Speed: 350 fpm max.	Tow Trolley	Cable Trolley	End Clamp
			
Main Rollers*	2.0" dia. steel flanged	2.0" dia. steel flanged	n/a
Anti-Lift Rollers	1.38 dia. steel	1.38" dia. steel	n/a
No. Required per Sytem	One - tow trolley is supplied with towing box for tow bar. Anti-lift rollers are req'd.	One per cable loop. Anti-lift rollers are optional	One - plus appropriate mounting clamp as determined by factory

*Spark resistant bronze rollers are available for hazardous locations - consult the factory

	Saddle		Unit Length	Cable Window		Zinc Plated Part No.	Stainless Steel Part No.	Wt. #
	Dia.	Width		Width (in.)	S1 Hgt. (in.)*			
Tow Trolley	4	5 1/4	11 1/8	3.9	0.4	45103	45116	17.0
Cable Trolley	4	5 1/4	8 5/8	3.9	0.4	45129	45143	13.0
End Trolley	4	5 1/4	7 3/8	3.9	0.4	45156	45169	11.0
Tow Trolley	4	8	11 1/8	6.7	0.4	45103B	45116B	17.0
Cable Trolley	4	8	8 5/8	6.7	0.4	45129B	45143B	13.0
End Trolley	4	8	7 3/8	6.7	0.4	45156B	45169B	11.0
Tow Trolley	6	5 1/4	12 5/8	3.9	0.6	45108	45119	17.0
Cable Trolley	6	5 1/4	10 1/8	3.9	0.6	45134	45146	13.0
End Trolley	6	5 1/4	8 7/8	3.9	0.6	45161	45172	11.0
Tow Trolley	6	8	12 5/8	6.7	0.6	45108B	45119B	17.0
Cable Trolley	6	8	10 1/8	6.7	0.6	45134B	45146B	13.0
End Trolley	6	8	8 7/8	6.7	0.6	45161B	45172B	11.0
Tow Trolley	8	5 1/4	11 1/8	3.9	0.8	45111	45124	17.0
Cable Trolley	8	5 1/4	8 5/8	3.9	0.8	45137	45151	13.0
End Trolley	8	5 1/4	7 3/8	3.9	0.8	45164	45177	11.0
Tow Trolley	8	8	15 1/8	6.7	0.8	45111B	45124B	17.0
Cable Trolley	8	8	12 5/8	6.7	0.8	45137B	45151B	13.0
End Trolley	8	8	11 3/8	6.7	0.8	45164B	45177B	11.0

Running Gear for W-Beams

Without Anti-Lift Rollers: **45195*** (SS: **45200***)

With Anti-Lift Rollers: **45196*** (SS: **Consult Factory**)

Beam	Code	Beam	Code
W4 x 13	A	W6 x 9	D
W5 x 16	B	W6 x 12	E
W5 x 19	C	W8 x 10	K

Running Gear for S-Beams

Without Anti-Lift Rollers: **45185*** (SS: **45190***)

With Anti-Lift Rollers: **45186*** (SS: **44853***)

Beam	Code	Beam	Code
S4 x 7.7	C	S6 x 12.5	G
S4 x 9.5	D	S6 x 17.25	H
S5 x 10.0	E	S7 x 15.3	J

* Insert Code Letter to indicate beam size. For other beam sizes consult factory.

For the most current and up to date information visit our website at:

www.conductix.us

Festoon Accessories

CONDUCTIX offers a complete selection of accessories for your festoon system, including a variety of push-button pendants to maximize the value of your system.

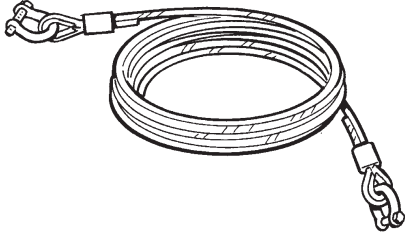
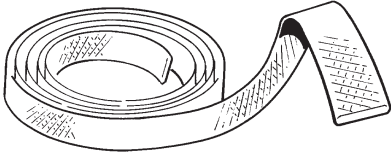
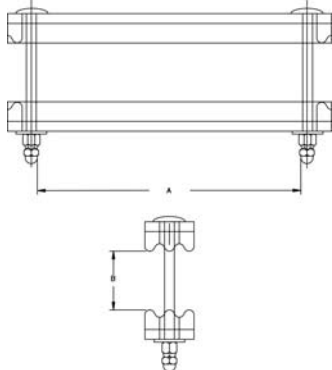
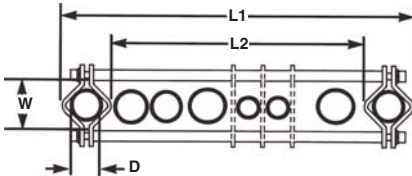
	Part No.	Length	Nominal Weight (lbs.)	Description																	
	44600	4' - 6'	.28	Tow Cable Optional item used in both High Speed and Outdoor applications. Designed for use on: <ul style="list-style-type: none"> ● Heavy Duty C-Track - 8" Trolleys only. ● Heavy Duty Square Bar ● 250 Series "I" Beam ● 350 Series "I" Beam 																	
	44600B	6' - 8'	.40																		
	44600C	8' - 10'	.51																		
	44600D	10' - 12'	.63																		
	44600E	12' - 14'	.74																		
	44600F	14' - 16'	.85																		
	03159	As Required	.18 lbs. per ft.	Tow Webbing Optional item used in both high speed and outdoor applications, ideal for systems in spark resistant environments. Ordered by the foot. Designed for use on: <ul style="list-style-type: none"> ● Standard Duty C-Track ● Standard Duty Square Bar ● 200 Series "I" Beam ● 225 Series "I" Beam 																	
	<table border="1"> <thead> <tr> <th rowspan="2">Catalog Number</th> <th colspan="2">Dimensions: Inches</th> </tr> <tr> <th>A</th> <th>B</th> </tr> </thead> <tbody> <tr> <td>22243</td> <td>4.0"</td> <td>1.5"</td> </tr> <tr> <td>43957</td> <td>6.7"</td> <td>1.5"</td> </tr> <tr> <td>43957B</td> <td>6.7"</td> <td>2.0"</td> </tr> </tbody> </table>			Catalog Number	Dimensions: Inches		A	B	22243	4.0"	1.5"	43957	6.7"	1.5"	43957B	6.7"	2.0"	Flat Cable Organizer Optional item for systems in order to prevent flat cables within the loops from becoming tangled or caught during operation. Designed for use on: <ul style="list-style-type: none"> ● 200 Series "I" Beam ● 225 Series "I" Beam ● 250 Series "I" Beam ● 350 Series "I" Beam ● Can also be used on other festoon systems depending upon application 			
Catalog Number	Dimensions: Inches																				
	A	B																			
22243	4.0"	1.5"																			
43957	6.7"	1.5"																			
43957B	6.7"	2.0"																			
	<table border="1"> <thead> <tr> <th rowspan="2">Catalog Number</th> <th rowspan="2">"D" Cable Dia. Range</th> <th rowspan="2">L1</th> <th rowspan="2">L2</th> <th>Wt</th> </tr> <tr> <th>(lbs.)</th> </tr> </thead> <tbody> <tr> <td>40600P</td> <td>Up to .80</td> <td>6.0"</td> <td>3.9"</td> <td>.75</td> </tr> <tr> <td>40600Q</td> <td>Up to .80</td> <td>8.8"</td> <td>6.7"</td> <td>1.1</td> </tr> </tbody> </table>				Catalog Number	"D" Cable Dia. Range	L1	L2	Wt	(lbs.)	40600P	Up to .80	6.0"	3.9"	.75	40600Q	Up to .80	8.8"	6.7"	1.1	Round Cable Organizer Optional item for systems in order to prevent round cables within loops from becoming tangled or caught during operation. Either one or two per loop may be required. Designed for use on: <ul style="list-style-type: none"> ● 200 Series "I" Beam ● 225 Series "I" Beam ● 250 Series "I" Beam ● 350 Series "I" Beam ● Can also be use on other festoon systems depending upon application.
	Catalog Number	"D" Cable Dia. Range	L1	L2					Wt												
(lbs.)																					
40600P	Up to .80	6.0"	3.9"	.75																	
40600Q	Up to .80	8.8"	6.7"	1.1																	

Control Trolley Junction Boxes and Terminal Strips

CONDUCTIX offers several standard junction box / terminal strip combinations for use with Control Box Trolleys (pgs. 13, 16, 18 and 22). If you don't see the junction box you need, please contact the factory. See pg. 29 for "Quick Disconnect connectors", which can be used instead of hard-wired junction box.

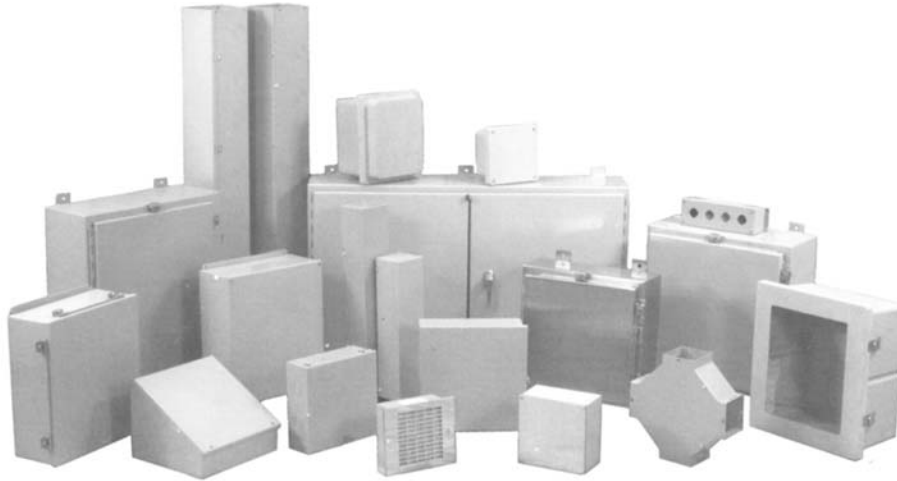

Size (in.)	NEMA*	Terminal Strips Included	Material	Part No.	Weight
10 x 8 x 6	12	None	Painted Steel	34905	10.5 lbs.
10 x 8 x 6	12	12 Pole Control, 8 Pole Control	Painted Steel	39362	10.5 lbs.
10 x 8 x 6	12	12 Pole Control	Painted Steel	39412	10.5 lbs.
10 x 8 x 6	12	24 Pole Control	Painted Steel	39413	10.5 lbs.
10 x 8 x 6	4	None	Painted Steel	03982	10.0 lbs.
10 x 8 x 6	4	12 Pole Power, 8 Pole Control	Painted Steel	39362B	10.0 lbs.
10 x 8 x 6	4	12 Pole Control	Painted Steel	39412B	10.0 lbs.
10 x 8 x 6	4	24 Pole Control	Painted Steel	39413B	10.0 lbs.
10 x 8 x 6	4X	None	Stainless Steel	39406	9.5 lbs.
10 x 8 x 6	4X	12 Pole Power, 8 Pole Power	Stainless Steel	39362C	9.5 lbs.
10 x 8 x 6	4X	12 Pole Control	Stainless Steel	39412C	9.5 lbs.
10 x 8 x 6	4X	24 Pole Control	Stainless Steel	39413C	9.5 lbs.
10 x 8 x 6	4X	8 Pole Power	Stainless Steel	39415	9.5 lbs.
12 x 12 x 6	12	None	Painted Steel	39407	14.5 lbs.
12 x 12 x 6	12	36 Pole Control	Painted Steel	36412	14.5 lbs.
12 x 12 x 6	12	24 Pole Control, 8 Pole Power	Painted Steel	39388	14.5 lbs.
12 x 12 x 6	4	None	Painted Steel	38866	14.9 lbs.
12 x 12 x 6	4	36 Pole Control	Painted Steel	36412B	14.9 lbs.
12 x 12 x 6	4	As Drilled	Painted Steel	38870	14.9 lbs.
12 x 12 x 6	4	24 Pole Control, 8 Pole Power	Painted Steel	39388B	14.9 lbs.
12 x 12 x 6	4X	None	Stainless Steel	39408	13.5 lbs.
12 x 12 x 6	4X	36 Pole Control	Stainless Steel	36412C	13.5 lbs.
12 x 12 x 6	4X	24 Pole Control, 8 Pole Power	Stainless Steel	39388C	13.5 lbs.
14 x 12 x 6	12	None	Painted Steel	39105	16.4 lbs.
14 x 12 x 6	12	48 Pole Control	Painted Steel	35527	16.4 lbs.
14 x 12 x 6	12	36 Pole	Painted Steel	39109	16.4 lbs.
14 x 12 x 6	12	36 Pole Control, 8 Pole Power	Painted Steel	39394	16.4 lbs.
14 x 12 x 6	12	36 Pole Control, 8 Pole Power	Painted Steel	39882	16.4 lbs.
14 x 12 x 6	4	None	Painted Steel	39409	16.9 lbs.
14 x 12 x 6	4	48 Pole Control	Painted Steel	35527B	16.9 lbs.
14 x 12 x 6	4	36 Pole Control, 8 Pole Power	Painted Steel	39394B	16.9 lbs.
14 x 12 x 6	4X	None	Stainless Steel	39410	15.0 lbs.
14 x 12 x 6	4X	48 Pole Control	Stainless Steel	35527C	15.0 lbs.
14 x 12 x 6	4X	36 Pole Control, 8 Pole Power	Stainless Steel	39394C	15.0 lbs.

*See pg. 6 for descriptions of NEMA ratings

For the most current and up to date information visit our website at:

www.conductix.us

Push Button Pendants



Push Button Pendants are used in conjunction with hard-wired control festoon systems. **CONDUCTIX** offers a complete line of Push Button Pendants and Radio Controls.

Ask for Pendant & Radio Catalog to get all the details, or download it from our website - www.conductix.us

“Quick Disconnect” Pin Connectors



In most industrial environments, Push Button Pendants take a lot of abuse. Eventually, they will need to be replaced. When a pendant station has to be replaced, the biggest concerns are always:

- Equipment downtime
- Expense
- Risk of injury to maintenance personnel

CONDUCTIX has the solution to reduce all three of these concerns - the “Quick Disconnect” Pin Connector.

Pendants wired with “Quick Disconnect” Pin Connectors can be replaced in as little as 5 to 10 minutes, versus two hours with a hard-wired pendant. A positive latch mechanism keeps the connector plugged in until you’re ready to disconnect the pendant.

The quick-disconnect connectors are available in 16 and 24 pin versions.

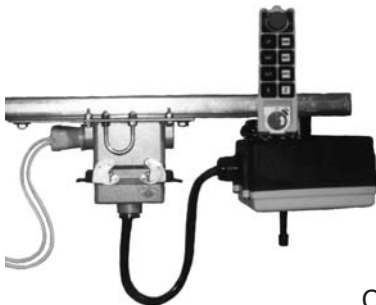

You can use Quick Disconnects with radio controls as well. Then you can switch from radio control to a standard pendant quickly and easily.

Contact **CONDUCTIX** for more information and a quotation on the Quick Disconnect

For the most current and up to date information visit our website at:
www.conductix.us

Heavy Duty I-Beam Festoons

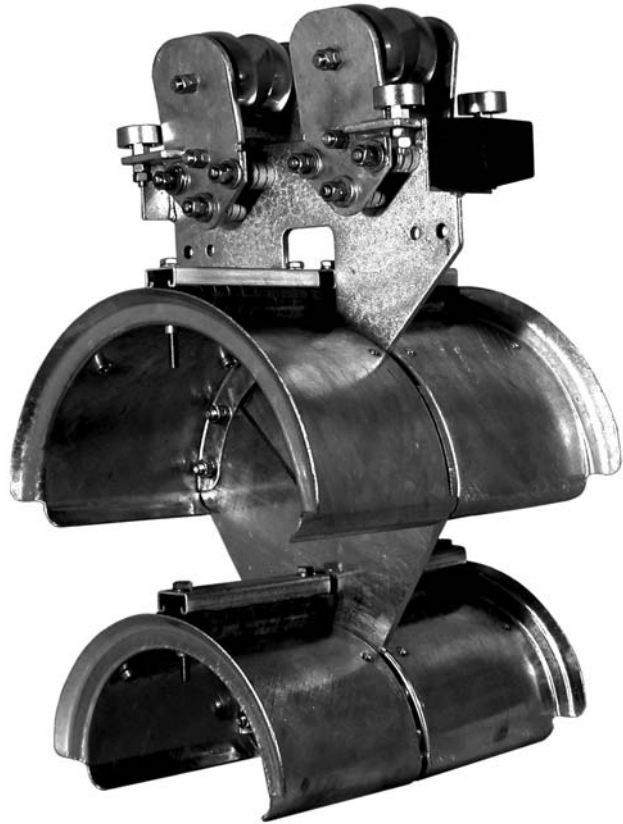

CONDUCTIX Heavy Duty Festoon systems are ideal for rough-duty industrial applications to include:

- Port Container Cranes and other large gantry cranes
- Steel mill cranes
- Foundry cranes
- Aluminum handling cranes
- Bulk Material Handling Conveyors

These systems run on customer-supplied I-beams and are available in a variety of configurations to manage long and heavy cable packages. Cable Trolleys can be built with one-tier, two-tier, or three tier cable saddles. Systems can be configured to handle speeds of up to 500 feet per minute.

For a System Overview, see pgs. 32-33
For Trolley Construction Details, see pg. 38
For Available Accessories, see pgs. 48-52



Heavy Duty I-Beam Festoon

There are five basic steps required to layout a Heavy Duty festoon system. Specific information regarding each step can be found on the accompanying pages.

Step I: Application Information All pertinent facts regarding the crane, its electrical requirements and duties, are required to properly size the festoon system. You can use the specification checklist on pgs. 4-5 to collect and communicate this information.

Step II: Cable Selection and Arrangement In order to satisfy the electrical requirement of the crane, the number, the size of conductors and the type of cable must be determined. Once determined, they must then be arranged in an order that is suitable for the constant work (flexing) required during operation.

Step III: Trolley Selection Method to determine a suitable trolley carrier that will not only protect the electrical cables, but also meet the physical demands of the application.

Trolley selection is based on the minimum bend diameter of the cable to be festooned. Minimum allowable cable saddle diameter is 10 times the O.D. of the largest cable in the cable package. After determining cable saddle diameter, a saddle width must be specified by determining the maximum width of the cable package.

Step IV: System Calculations Required to determine the length of cables and the number of trolleys required to meet the application requirements.

Step V: System Accessories Items that may be required in order to enhance the performance of the festoon system.

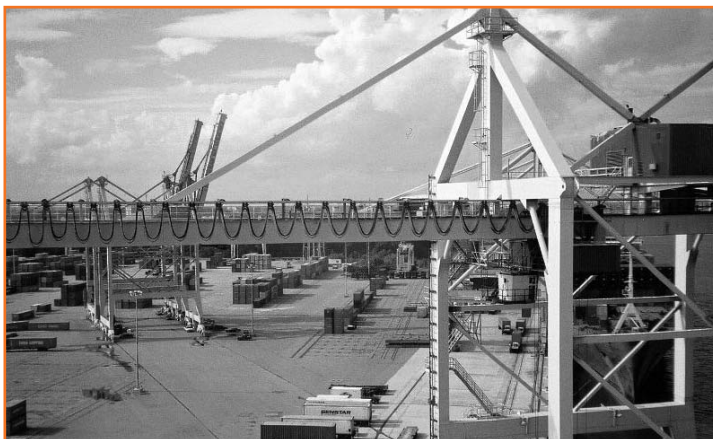

CONDUCTIX Festoon System on a Container Crane



Closeup shot of the same crane.

Heavy Duty Festoon Overview

Terms & Definitions

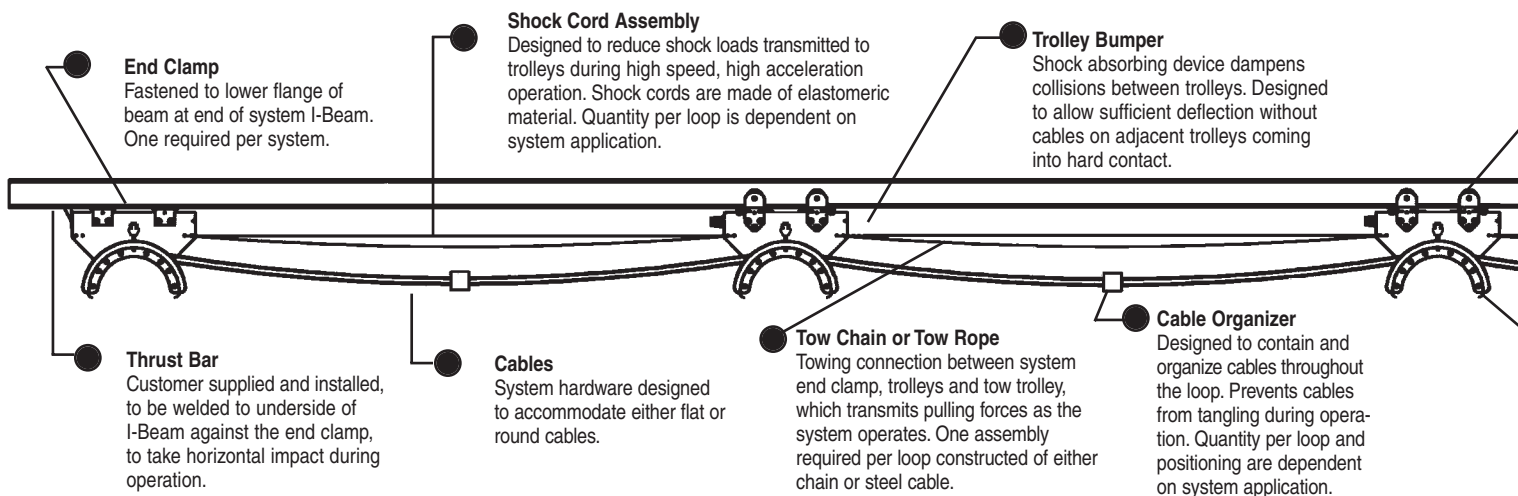
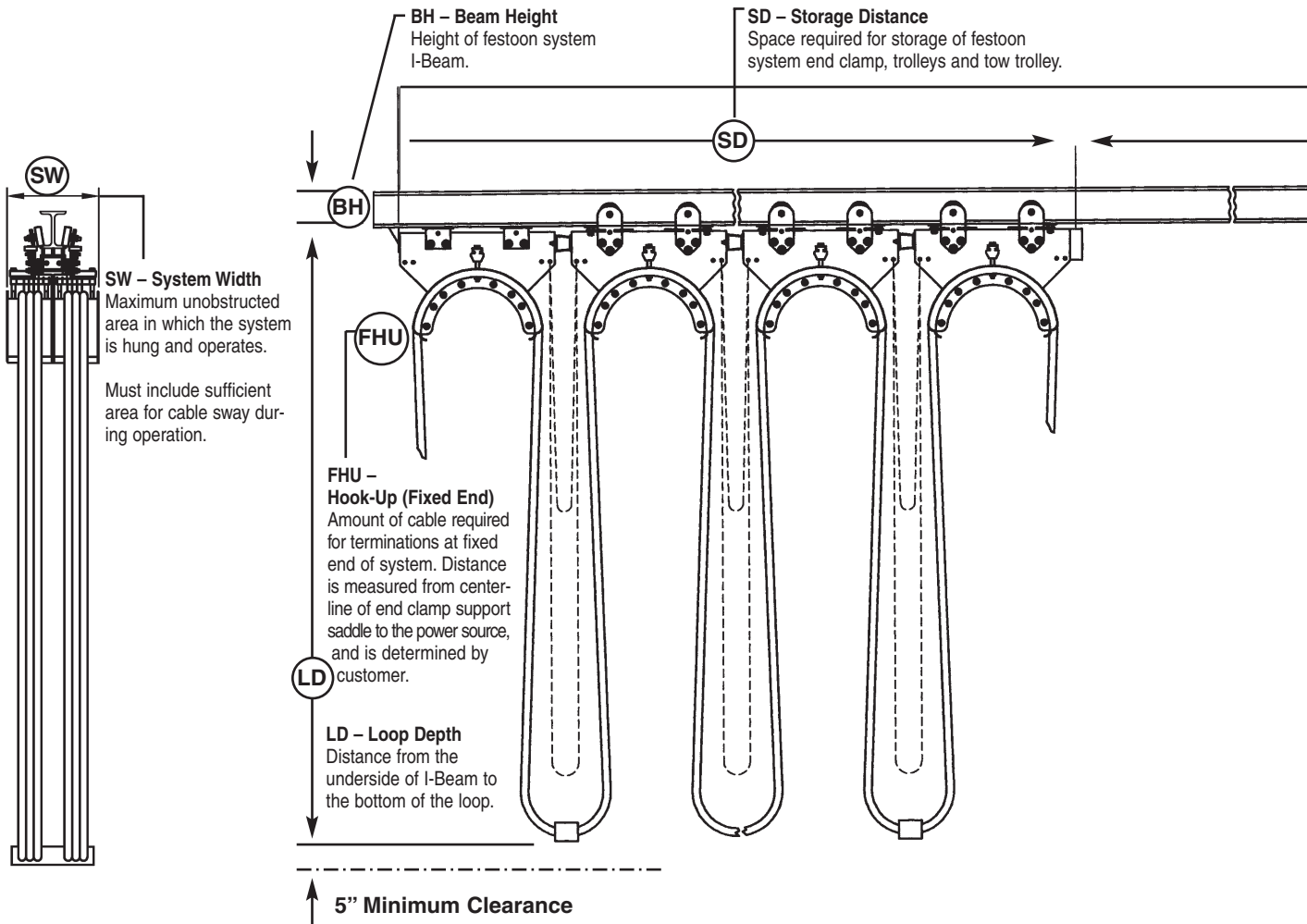

Heavy Duty Festoon Overview

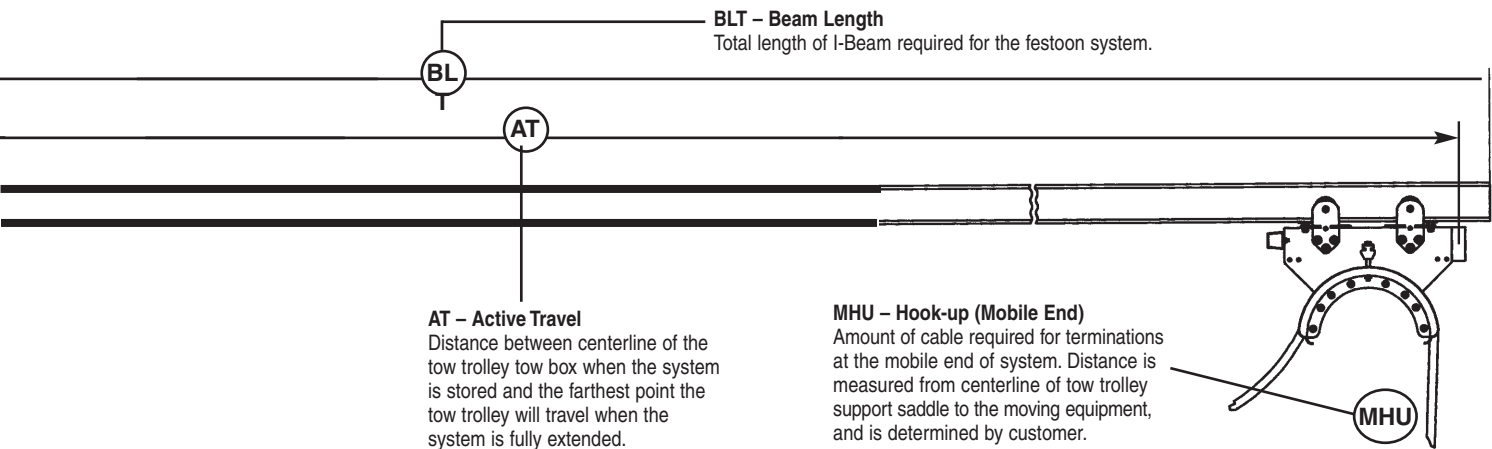

- ◆ Festoon systems are designed to provide electrical power and control signals from a fixed source to a moving consumer. This is accomplished by placing the electrical cables on supports (trolleys) which are free to travel in conjunction with the moving consumer.
- ◆ CONDUCTIX Heavy-Duty Festoon system is designed to provide the utmost protection and care for the electric cables which are the lifeblood of the system. This protection equates to longer cable life, lower maintenance costs, and lower overall operating expenses.

The layout below depicts a typical festoon system, the key components, terms and definitions.

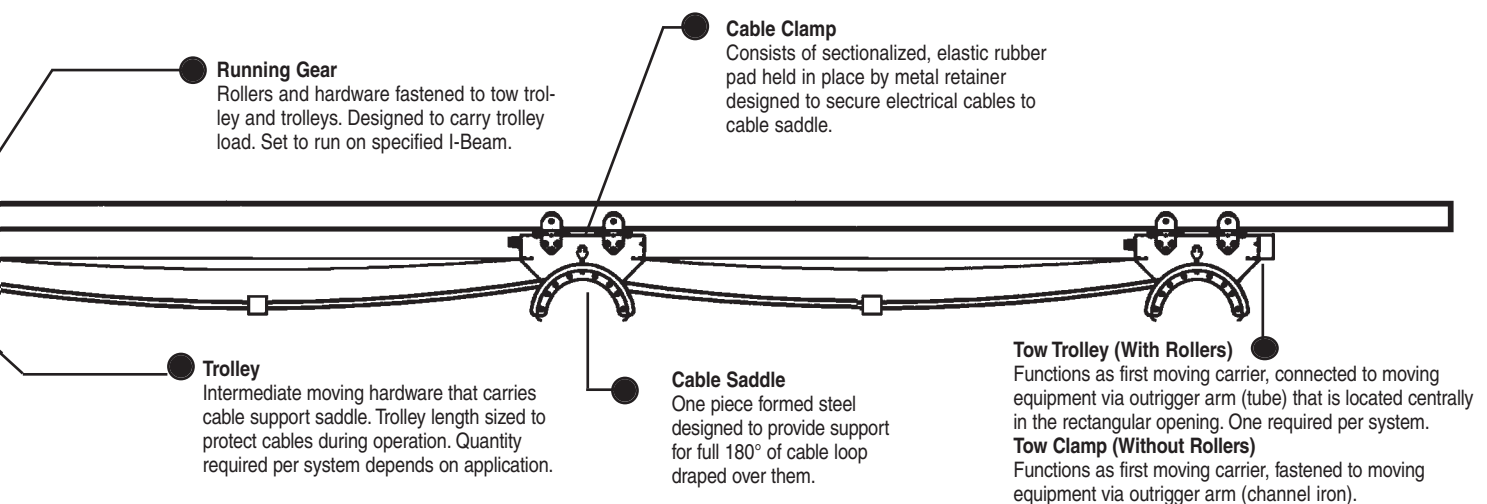

Step 1: Specification Information Form from pages: 4-5

Step 2: Cable Selection & Arrangement

The first step in designing a festoon system begins with the electrical cables - the type size and number of conductors.

Either flat or round cables or a combination of the two can be selected. Generally, it is recommended to use either all round or all flat for a system. However, depending on the application and the actual combination, equipment can be selected to accommodate both types. Care should be taken when selecting round cables as some cables are not suited for the constant flexing required. Highly stranded round cables are recommended as they are designed to have the flexibility required to meet the demands of the system. The next step is to prepare a sketch on paper of how the cables are to be arranged on the support saddles. Here are some general guidelines to follow:

Flat Cables:

- 1) Cables should be arranged such that the larger conductor sized cables (power cables) are on top of the stack. (See diagram.) This provides a larger bending radius, as well as improving heat dissipation. Since the top cable also takes more pulling force during operation, the larger conductor placed on top is better suited to handle this force.
- 2) Cable packages should be arranged with a width to height ratio of 3 or 4 to 1. Tall and narrow cable stacks can be unstable during operation.
- 3) Cables should be arranged such that a minimum of 50% of each cable surface is under clamp pressure. (See diagram.)

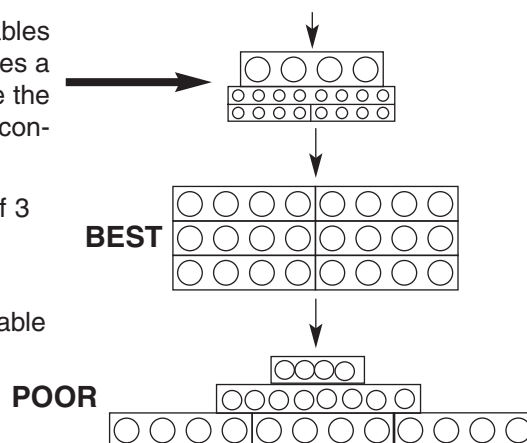

Round Cables:

- 1) Cable diameter variations should be kept to a minimum. Large deviations in diameters makes clamping difficult and they may not remain secure during operation, see diagram.
- 2) Cables should be arranged in the following order: 1) The two largest cables are placed in the outer most positions of the support saddle. 2) The remaining cables are then arranged between these two cables, taking care to place the heaviest cables near the centerline of the trolley and the lighter cables to the outer positions, see diagram. It is recommended to distribute the cable load evenly as this is important for smooth running and longer bearing life.

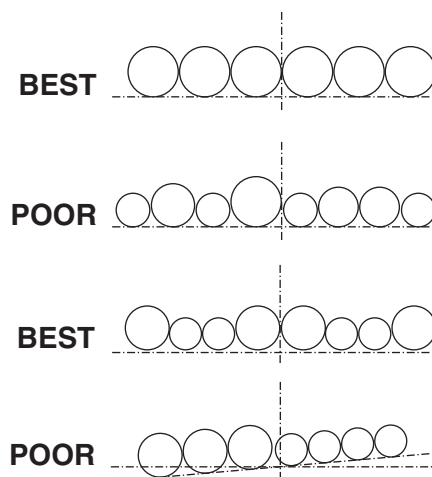

Combination Flat & Round Cables:

Cable should be arranged in the following order:

- 1) Large round cables placed on the outer most positions of the cable saddle. Flat cables arranged between the round cables. Distribute weight evenly on both saddles. Use round cable organizers.

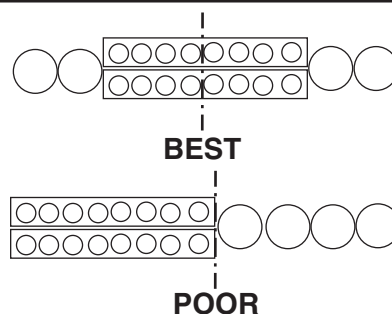

Step 3: Trolley Selection

Trolley Selection consists of the following steps: 1) selecting the proper body size, 2) selecting the proper style of running gear, and 3) determining the proper main roller size.

- 1) Body size selection is determined by the cable arrangement prepared earlier, and is based primarily on the diameter of the support saddle. Saddles are designed to provide support for the full 180° loops of cable which are draped over them. This eliminates the stress on the cable at the saddle edges where the cable begins to hang straight. The rules for proper saddle diameter selection are:

For Flat Cables:

Cable thickness up to .316": Saddle diameter \geq 6.3 x Cable thickness

Cable thickness up to .500": Saddle diameter \geq 8 x Cable thickness

Cable thickness over .500": Saddle diameter \geq 10 x Cable thickness

For Round Cables:

Saddle diameter \geq 10 x Largest cable diameter

For dimensional information of trolleys, tow trolleys, etc. see pages 12, 13 & 14.

- 2) The style of running gear to be selected depends on the application. The following are the recommended guidelines:

Running Gear	Application
Crowned Main Rollers + Horizontal Guide Rollers	<ul style="list-style-type: none"> * Indoor operation * Moderate speeds, any duty cycle * Outdoor operation if no possibility of ice on beam.
Crowned Main Rollers + Horizontal Guide Rollers + Anti-Lift Rollers	<ul style="list-style-type: none"> * All speeds and duty cycles * Use where side winds/lateral forces could cause trolley to tip. * Especially useful on multiple tier trolleys and beams with narrow flanges. * Anti-Lift rollers required on all Tow Trolleys.
Flanged Main Rollers	<ul style="list-style-type: none"> * Indoor operation * Moderate speeds - any duty cycle
Flanged Main Rollers + Anti-Lift Rollers	<ul style="list-style-type: none"> * Moderate speeds and any duty cycle * Use where side winds/lateral forces could cause trolley to tip. * Especially useful on multiple tier trolleys and beams with narrow flanges. * Anti-Lift rollers required on all Tow Trolleys.

See pages 17 thru 20 for running gear part numbers

System Design

Step 3: Trolley Selection (continued)

- 3) Proper main roller size is based on the mean operating speed of the festoon system, the running time per day and the load per trolley.

The following charts will help determine the size (diameter) of the main roller based on these factors. Please note that the standard rollers are made of hardened steel, however for special applications, rollers with polyurethane tires are also available. These are suited for applications where quiet operation is required and minimal wear of the running beam is desired.

Hardened Steel

Speed		Mean Running Time per Day				
Ft. / Min.	M / Min.	(Hours)				
Up to 84	25	4 to 8	8 to 16	Over 16		
84-175	25-53	2 to 4	4 to 8	8 to 16	Over 16	
175-326	53-100	Up to 2	2 to 4	4 to 8	8 to 16	Over 16
326-500	100-152		Up to 2	2 to 4	4 to 8	8 to 16
Main Roller Diameter		Load per Trolley				
Inches	MM	Pounds (Kg)				
2.5	62	450 (204)	350 (159)	275 (125)	225 (102)	175 (79)
4	100	1100 (500)	900 (408)	750 (340)	575 (261)	450 (204)

Polyurethane Tired

Speed		Mean Running Time per Day				
Ft. / Min.	M / Min.	(Hours)				
Up to 84	25	4 to 8	8 to 16	Over 16		
84-175	25-53	2 to 4	4 to 8	8 to 16	Over 16	
175-326	53-100	Up to 2	2 to 4	4 to 8	8 to 16	Over 16
326-500	100-152		Up to 2	2 to 4	4 to 8	8 to 16
Main Roller Diameter		Load per Trolley				
Inches	MM	Pounds (Kg)				
2.5	62	315 (143)	245 (111)	190 (86)	155 (70)	120 (55)
4	100	770(350)	630 (286)	340 (155)	400 (182)	315 (143)

- Steps:**
- 1) Select system operating speed
 - 2) Follow line to right to the column displaying appropriate running time per day
 - 3) Follow column down to line displaying appropriate load per trolley
(approximate load = [loop depth (ft.) x 2] x total cable package weight lbs. / ft.)
 - 4) Follow line to left to determine main roller diameter

Step 4: System Calculations

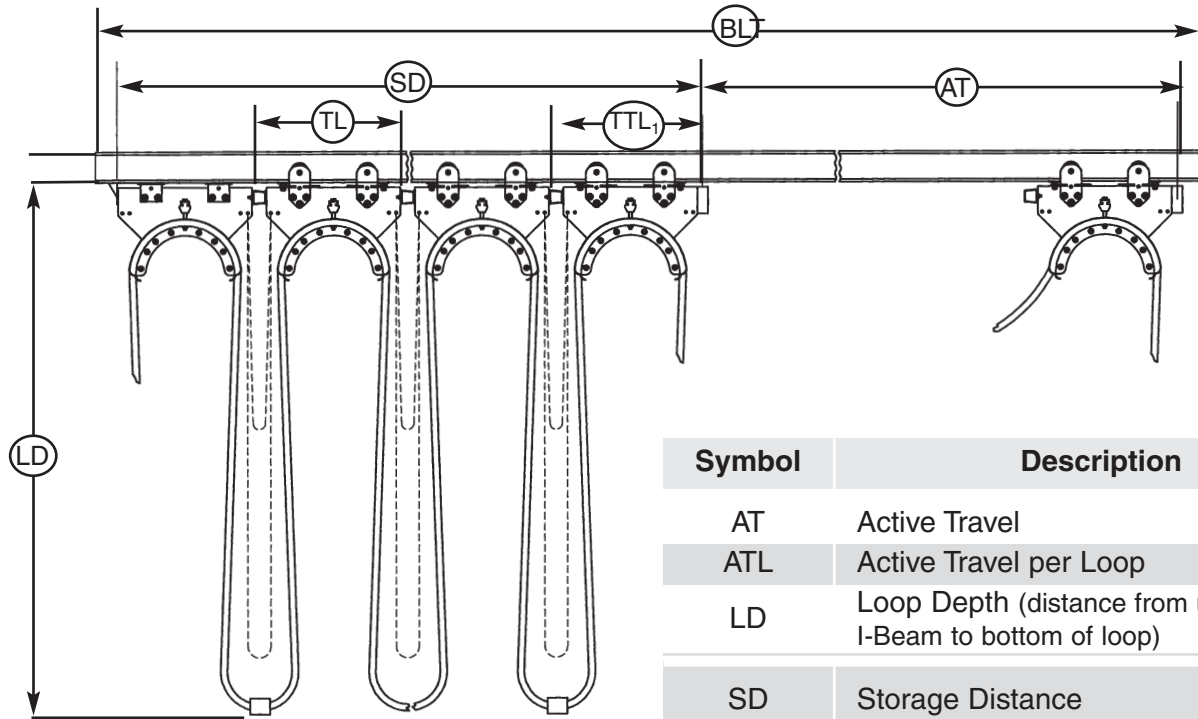

Cable Length per Loop
$CL = 2 \times LD$
Active Travel per Loop
$ATL = (CL \times SF) - TL$
Number of Loops
$NL = AT / ATL$
Total Cable Length
$TCL = CL \times NL$
Storage Distance
$SD = (NL \times TL) + TTL_1$

Symbol	Description
AT	Active Travel
ATL	Active Travel per Loop
LD	Loop Depth (distance from underside of I-Beam to bottom of loop)
SD	Storage Distance
TL	Trolley Length
TTL ₁	Tow Trolley Length (measured from bumper to center line of tow box)
SF	Cable Sag Factor
CL	Cable Required per Loop
TCL	Total Cable Length (does not include hook-up footages)
NL	Number of Loops Required

CABLE SAG FACTOR CHART

Speed Ft/min (M/min)	LOOP DEPTH -- FT. (M)					
	up to 2.5 (up to 0.76)	2.51 to 4.0 (0.77 to 1.21)	4.01 to 6.5 (1.22 to 1.98)	6.5 to 10.5 (1.99 to 3.2)	10.51 to 16.5 (3.21 to 5.03)	16.51 to 26 (5.04 to 7.9)
0-105 (0-32)	0.90	0.90	0.90	0.90	0.90	0.90
105-130 (32-40)	0.85	0.90	0.90	0.90	0.90	0.90
130-160 (40-50)	0.80	0.85	0.90	0.90	0.90	0.90
165-205 (50-63)	0.75	0.80	0.85	0.90	0.90	0.90
205-260 (63-80)		0.75*	0.80	0.85	0.90	0.90
260-330 (80-100)			0.75*	0.80	0.85	0.90
330-410 (100-125)				0.75*	0.80	0.85
410-500 (125-152)						

*Shock cords are recommended. See pages 23 & 24 for details.

Trolley Construction/Specifications/Features

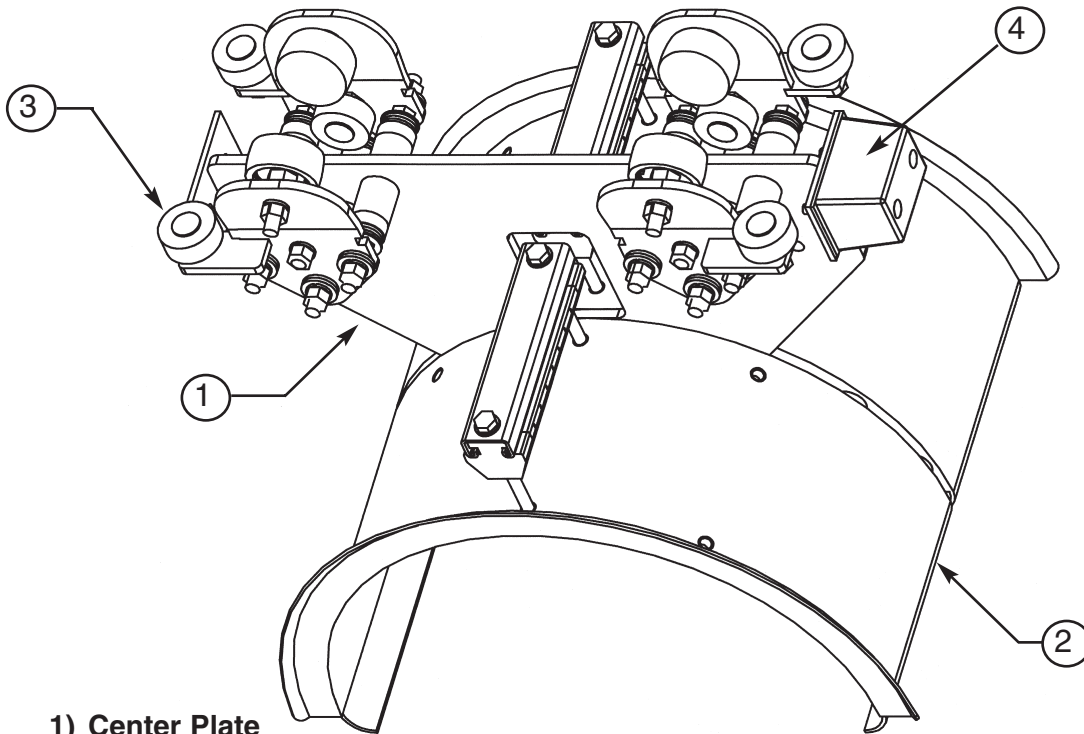

1) Center Plate

Material: 3/8" Hot Rolled Steel
Finish: Hot Dipped Galvanized

2) Saddle Assembly

Material: 12 Gauge Steel
Finish: Hot Dipped Galvanized
Features: • Formed Saddle from single piece of steel, no welds
• Saddle has rolled flanges with rounded edges, won't cut cables
• Saddles bolted to center plate with stainless steel fastener
• Saddles available with either single or double cable clamping bar

3) Running Gear

Side Shields:

Material: 5/16" Hot Rolled Steel
Finish: Hot Dipped Galvanized
Features: • Bolted to center plate with stainless steel fastener
• Independently removable

Rollers:

Material: Hardened Steel
Finish: Zinc Plated
Bearings: Permanently Sealed, Ball Bearings
Feature: Available with polyurethane tires for quiet travel and minimal beam wear

4) Bumper

Material: Neoprene Rubber
Durometer: 65-70 ShoreA
fastener: Stainless Steel
Feature: Large contact surface area

10" (260 mm) Saddle Diameter

Trolley

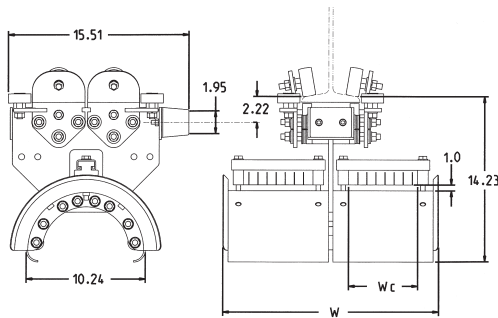

Part Number	"Wc" Inches (mm)	"W" Inches (mm)	Clamping Bar	Weight Lbs. (Kg)
40500A	6.00 (152)	18.50 (470)	Single	29 (13.2)
40500B	12.63 (320)	31.75 (806)	Single	39.5 (17.9)
40505A	6.00 (152)	18.50 (470)	Double	33.2 (15.1)
40505B	12.63 (320)	31.75 (806)	Double	46.7 (21.2)

Note: Running Gear is not included. Must be ordered separately. (See pages 17 thru 20.)

Tow Trolley

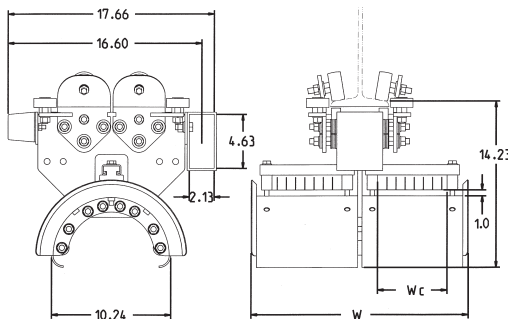

Part Number	"Wc" Inches (mm)	"W" Inches (mm)	Clamping Bar	Weight Lbs. (Kg)
40510A	6.00 (152)	18.50 (470)	Single	32.3 (14.6)
40510B	12.63 (320)	31.75 (806)	Single	42.8 (19.4)
40515A	6.00 (152)	18.50 (470)	Double	36.5 (16.6)
40515B	12.63 (320)	31.75 (806)	Double	50 (22.7)

Note: Running Gear is not included. Must be ordered separately. (See pages 17 thru 20.)

Tow Clamp

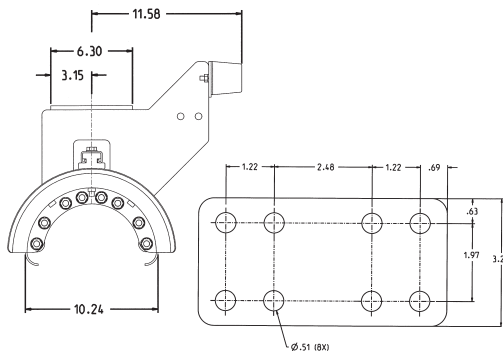

Part Number	"Wc" Inches (mm)	"W" Inches (mm)	Clamping Bar	Weight Lbs. (Kg)
40520A	6.00 (152)	18.50 (470)	Single	29 (13.2)
40520B	12.63 (320)	31.75 (806)	Single	39.5 (17.9)
40525A	6.00 (152)	18.50 (470)	Double	33.2 (15.1)
40525B	12.63 (320)	31.75 (806)	Double	46.7 (21.2)

End Clamp

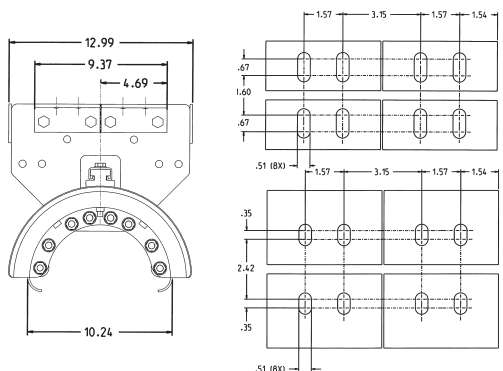

Part Number	"Wc" Inches (mm)	"W" Inches (mm)	Clamping Bar	Weight Lbs. (Kg)
40530A	6.00 (152)	18.50 (470)	Single	33.1 (15)
40530B	12.63 (320)	31.75 (806)	Single	43.6 (19.8)
40535A	6.00 (152)	18.50 (470)	Double	37.3 (16.9)
40535B	12.63 (320)	31.75 (806)	Double	50.8 (23)

14" (360 mm) Saddle Diameter

Trolley

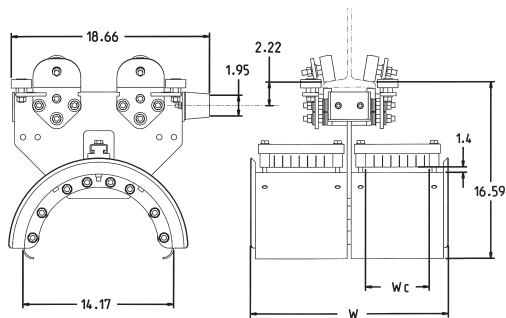

Part Number	"Wc" Inches (mm)	"W" Inches (mm)	Clamping Bar	Weight Lbs. (Kg)
40501A	6.00 (152)	18.50 (470)	Single	37 (16.8)
40501B	12.63 (320)	31.75 (806)	Single	49.9 (22.6)
40506A	6.00 (152)	18.50 (470)	Double	41.3 (18.7)
40506B	12.63 (320)	31.75 (806)	Double	57.2 (26)

Note: Running Gear is not included. Must be ordered separately. (See pages 17 thru 20.)

Tow Trolley

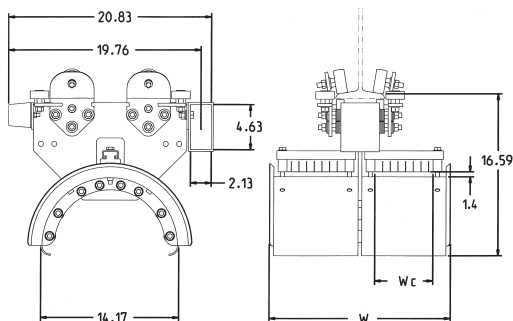

Part Number	"Wc" Inches (mm)	"W" Inches (mm)	Clamping Bar	Weight Lbs. (Kg)
40511A	6.00 (152)	18.50 (470)	Single	40.3 (18.3)
40511B	12.63 (320)	31.75 (806)	Single	53.2 (24.1)
40516A	6.00 (152)	18.50 (470)	Double	44.5 (20.2)
40516B	12.63 (320)	31.75 (806)	Double	60.5 (27.5)

Note: Running Gear is not included. Must be ordered separately. (See pages 17 thru 20.)

Tow Clamp

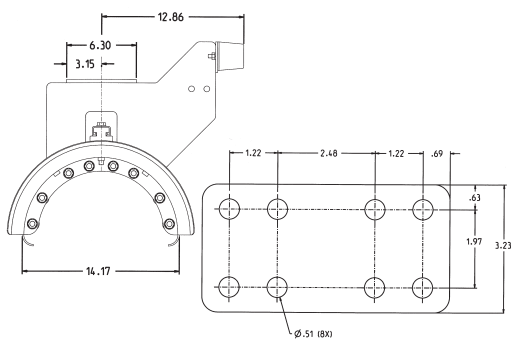

Part Number	"Wc" Inches (mm)	"W" Inches (mm)	Clamping Bar	Weight Lbs. (Kg)
40521A	6.00 (152)	18.50 (470)	Single	37.9 (17.2)
40521B	12.63 (320)	31.75 (806)	Single	50.8 (23)
40526A	6.00 (152)	18.50 (470)	Double	42.2 (19.1)
40526B	12.63 (320)	31.75 (806)	Double	58.1 (26.4)

End Clamp

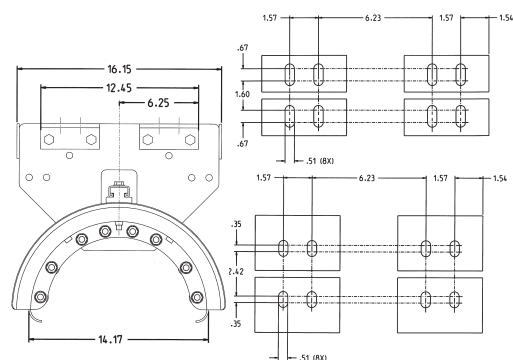

Part Number	"Wc" Inches (mm)	"W" Inches (mm)	Clamping Bar	Weight Lbs. (Kg)
40531A	6.00 (152)	18.50 (470)	Single	43.8 (19.9)
40531B	12.63 (320)	31.75 (806)	Single	55.1 (25)
40536A	6.00 (152)	18.50 (470)	Double	48 (21.8)
40536B	12.63 (320)	31.75 (806)	Double	64 (29)

19" (480 mm) Saddle Diameter

Trolley

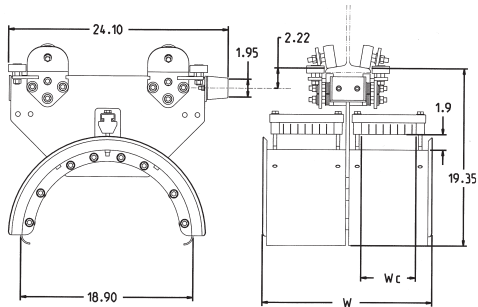

Part Number	"Wc" Inches (mm)	"W" Inches (mm)	Clamping Bar	Weight Lbs. (Kg)
40502A	6.00 (152)	18.50 (470)	Single	48.8 (22.1)
40502B	12.63 (320)	31.75 (806)	Single	64.7 (29.4)
40507A	6.00 (152)	18.50 (470)	Double	53.1 (24.1)
40507B	12.63 (320)	31.75 (806)	Double	71.9 (32.6)

Note: Running Gear is not included. Must be ordered separately. (See pages 17 thru 20.)

Tow Trolley

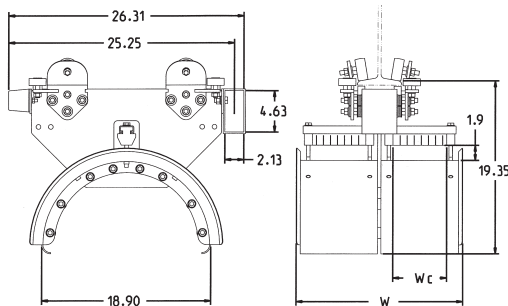

Part Number	"Wc" Inches (mm)	"W" Inches (mm)	Clamping Bar	Weight Lbs. (Kg)
40512A	6.00 (152)	18.50 (470)	Single	52.1 (23.6)
40512B	12.63 (320)	31.75 (806)	Single	68 (30.9)
40517A	6.00 (152)	18.50 (470)	Double	56.3 (25.5)
40517B	12.63 (320)	31.75 (806)	Double	75.2 (34.1)

Note: Running Gear is not included. Must be ordered separately. (See pages 17 thru 20.)

Tow Clamp

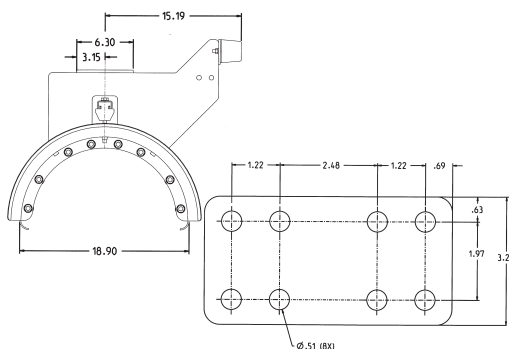

Part Number	"Wc" Inches (mm)	"W" Inches (mm)	Clamping Bar	Weight Lbs. (Kg)
40522A	6.00 (152)	18.50 (470)	Single	46.4 (21)
40522B	12.63 (320)	31.75 (806)	Single	62.3 (28.3)
40527A	6.00 (152)	18.50 (470)	Double	50.7 (23)
40527B	12.63 (320)	31.75 (806)	Double	69.6 (31.6)

End Clamp

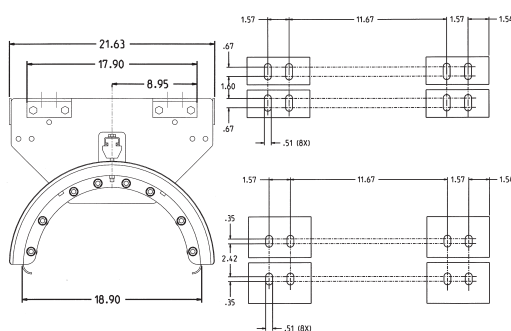

Part Number	"Wc" Inches (mm)	"W" Inches (mm)	Clamping Bar	Weight Lbs. (Kg)
40532A	6.00 (152)	18.50 (470)	Single	55.6 (25.2)
40532B	12.63 (320)	31.75 (806)	Single	71.4 (32.4)
40537A	6.00 (152)	18.50 (470)	Double	60 (27.2)
40537B	12.63 (320)	31.75 (806)	Double	78.7 (35.7)

Auxiliary Saddle

Auxiliary Saddle

In certain applications, additional saddles may be required:

- a) For large cable packages unable to fit on primary saddle or
- b) To separate power and control cables.

One or two additional saddles may be added, depending on the weight limit of the trolley.

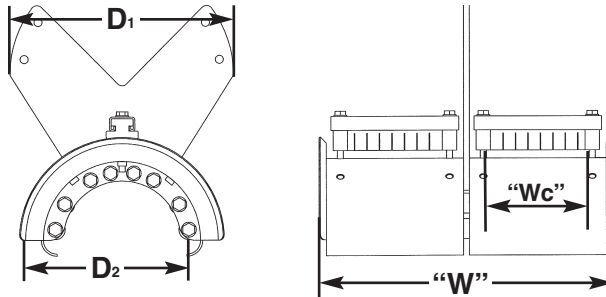

Part Number	D ₁ Inches (mm)	D ₂ Inches (mm)	"Wc" Inches (mm)	"W" Inches (mm)	Clamping Bar	Weight Lbs. (Kg.)
40570 A	10" (260)	10" (260)	6.00 (152)	18.50 (470)	Single	22.5 (10.2)
40570 B			12.63 (320)	31.75 (806)	Single	33 (15)
40715 A			6.00 (152)	18.50 (470)	Double	26.7 (12.1)
40715 B			12.63 (320)	31.75 (806)	Double	40.2 (18.3)
40571 A	14" (360)	10" (260)	6.00 (152)	18.50 (470)	Single	28 (12.7)
40571 B			12.63 (320)	31.75 (806)	Single	38.5 (17.5)
40717 A			6.00 (152)	18.50 (470)	Double	32.3 (14.6)
40717 B			12.63 (320)	31.75 (806)	Double	45.7 (20.7)
40572 A	19" (480)	10" (260)	6.00 (152)	18.50 (470)	Single	28.2 (12.8)
40572 B			12.63 (320)	31.75 (806)	Single	38.6 (17.5)
40718 A			6.00 (152)	18.50 (470)	Double	32.3 (14.6)
40718 B			12.63 (320)	31.75 (806)	Double	45.8 (20.8)
40573 A	14" (360)	14" (360)	6.00 (152)	18.50 (470)	Single	31 (14.1)
40573 B			12.63 (320)	31.75 (806)	Single	42.4 (19.2)
40719 A			6.00 (152)	18.50 (470)	Double	35.3 (16)
40719 B			12.63 (320)	31.75 (806)	Double	51.2 (23.2)
40574 A	19" (480)	10" (260)	6.00 (152)	18.50 (470)	Single	33.5 (15.2)
40574 B			12.63 (320)	31.75 (806)	Single	46.4 (21)
40720 A			6.00 (152)	18.50 (470)	Double	37.8 (17.1)
40720 B			12.63 (320)	31.75 (806)	Double	53.7 (24.4)
40575 A	19" (480)	19" (480)	6.00 (152)	18.50 (470)	Single	43.6 (19.8)
40575 B			12.63 (320)	31.75 (806)	Single	59.4 (27)
40721 A			6.00 (152)	18.50 (470)	Double	47.8 (21.7)
40721 B			12.63 (320)	31.75 (806)	Double	66.7 (30.3)

- Notes:**
- 1) Auxiliary support saddles are normally selected and ordered with initial order. However, they can be ordered separately for installation to existing systems if required.
 - 2) Certain configurations may require bumper extensions, see page 16 for details.

Bumper Extensions

Bumper Extensions

In some configurations, multi-tier trolleys must use bumper extensions to ensure cables on adjacent trolleys do not come into hard contact with one another during operation.

The chart below indicates which multi-tier trolleys require bumper extensions.

END CLAMP

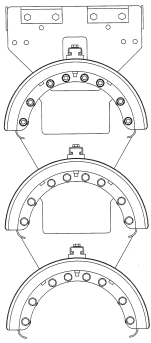

TROLLEY

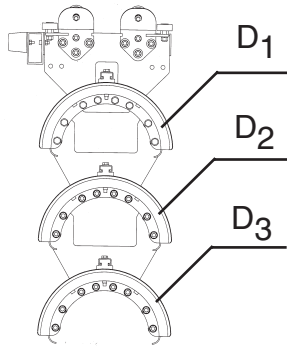

TOW TROLLEY

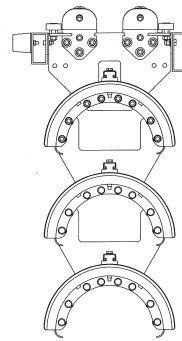

SIDE VIEW

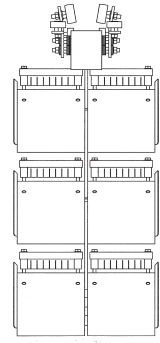

Saddle Arrangement	D ₁	D ₂	D ₃	Bumper Extension/ Mounting
	480	360	--	- / -
	480	260	--	- / -
	360	260	--	- / -
	480	480	--	Vertical / Vertical
	360	360	--	Horizontal / -
	260	260	--	- / -
	480	360	260	- / -
	480	360	360	Vertical / -
	480	260	260	- / -
	360	260	260	Vertical / -

The CONDUCTIX **Bumper Extension Kit (Part No. 40576)** may be mounted vertically and/or horizontally to add clearance for cables.

Each kit consists of one extension and mounting hardware. Order one kit per trolley and one additional kit for the tow trolley or tow clamp.

Mounting Orientation

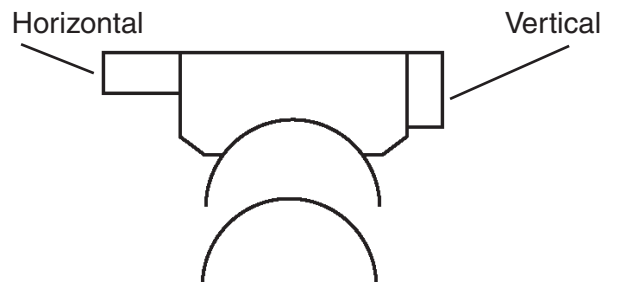

Running Gear for S Beams

Steel Main Rollers, Crowned

Running Gear

- Consists of (4) side shields with appropriate rollers, galvanized steel spacers and stainless steel fastener.
- Main rollers: *hardened steel, zinc plated with permanently sealed precision ball bearings.*
- Horizontal guide and anti-lift rollers: *zinc plated, sealed ball bearings.*
- Operating temperatures: -22° F to 220° F.
- Running gear designed for independent side shield removal.

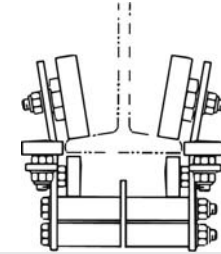
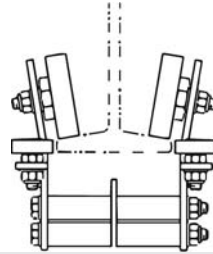

	With Horizontal Guide Rollers		With Horizontal Guide & Anti-Lift Rollers	
Main Roller Diameter In. (mm)	2.5" (62)	4" (100)	2.5" (62)	4" (100)
Maximum Load Lbs. (Kg)	450 (204)	1100 (500)	450 (204)	1100 (500)
Part Number	40546	40548	40551	40553
Weight Lbs. (Kg)	24.8 (11.2)	36.1 (16.4)	27.3 (12.4)	38.5 (17.5)

Steel Main Rollers, Crowned

Running Gear

- Consists of (4) side shields with appropriate rollers, galvanized steel spacers and stainless steel fastener.
- Main rollers: *hardened steel, zinc plated with permanently sealed precision ball bearings.*
- Anti-lift rollers: *zinc plated, sealed ball bearings.*
- Operating temperatures: -22° F to 220° F.
- Running gear designed for independent side shield removal.

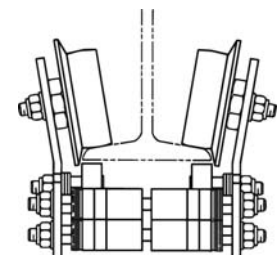
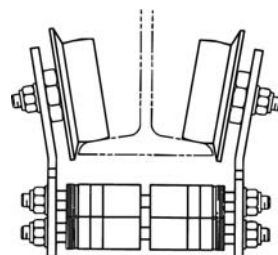

	Without Anti-Lift Rollers		With Anti-Lift Rollers	
Main Roller Diameter In. (mm)	2.5" (62)	4" (100)	2.5" (62)	4" (100)
Maximum Load Lbs. (Kg)	450 (204)	1100 (500)	450 (204)	1100 (500)
Part Number	40677	40678	40679	40680
Weight Lbs. (Kg)	24.8 (11.2)	36.1 (16.4)	27.3 (12.4)	38.5 (17.5)

Running Gear for S Beams

Steel Main Rollers, Polyurethane Tire

Running Gear

- Consists of (4) side shields with appropriate rollers, galvanized steel spacers and stainless steel fastener.
- Main rollers: *steel hub, zinc plated with permanently sealed precision ball bearings.*
- Horizontal guide and anti-lift rollers: *zinc plated steel with sealed ball bearings.*
- Operating temperatures: -22° F to 220° F.
- Running gear designed for independent side shield removal.



	With Horizontal Guide Rollers		With Horizontal Guide & Anti-Lift Rollers	
Main Roller Diameter In. (mm)	2.5" (62)	4" (100)	2.5" (62)	4" (100)
Maximum Load Lbs. (Kg)	315 (143)	770 (350)	315 (143)	770 (350)
Part Number	40547	40549	40552	40554
Weight Lbs. (Kg)	23.3 (10.6)	31.3 (14.2)	24.4 (11.1)	33.7 (15.3)

Ordering Instructions

How To Order Running Gear:

Running gear is assembled to the trolleys and tow trolleys at the factory. They are set to the nominal dimension of the I-beam of choice.

- Choose the appropriate running gear type and roller diameter.
- Add the corresponding suffix of the beam size to the base running gear number.

Example: 40551E = Running gear with 2.5" dia. steel main roller with horizontal guide and anti-lift rollers set for S5x10.0 I-beam.

Beam Size	Part Number Suffix	Beam Size	Part Number Suffix
S4 x 7.7	*C	S8 x 18.4	L
S4 x 9.5	*D	S8 x 23.0	M
S5 x 10.0	E	S10 x 25.4	N
S5 x 14.75	F	S10 x 35.0	P
S6 x 12.5	G	S12 x 31.8	Q
S6 x 17.25	H	S12 x 35.0	R
S7 x 15.3	J	S15 x 42.9	U
S7 x 20.0	K	S15 x 50.0	V

* NOTE: Suffix code C & D are not applicable for running gear with 4" dia. Main Roller.

Running Gear for W Beams

Steel Main Rollers, Crowned

Running Gear

- Consists of (4) side shields with appropriate rollers, galvanized steel spacers and stainless steel fastener.
- Main rollers: *hardened steel, zinc plated with permanently sealed precision ball bearings.*
- Horizontal guide and anti-lift rollers: *zinc plated, sealed ball bearings.*
- Operating temperatures: -22° F to 220° F.
- Running gear designed for independent side shield removal.

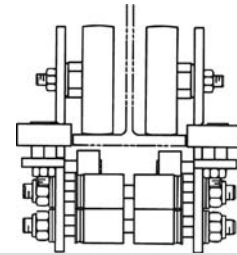
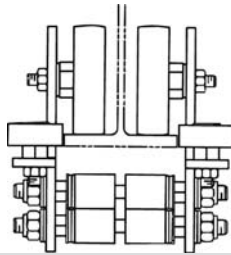

	With Horizontal Guide Rollers		With Horizontal Guide & Anti-Lift Rollers	
Main Roller Diameter In. (mm)	2.5" (62)	4" (100)	2.5" (62)	4" (100)
Maximum Load Lbs. (Kg)	450 (204)	1100 (500)	450 (204)	1100 (500)
Part Number	40556	40558	40560	40562
Weight Lbs. (Kg)	24.8 (11.2)	36.1 (16.4)	27.3 (12.4)	38.5 (17.5)

Steel Main Rollers, Flanged

Running Gear

- Consists of (4) side shields with appropriate rollers, galvanized steel spacers and stainless steel fastener.
- Main rollers: *hardened steel, zinc plated with permanently sealed precision ball bearings.*
- Anti-lift rollers: *zinc plated, sealed ball bearings.*
- Operating temperatures: -22° F to 220° F.
- Running gear designed for independent side shield removal.

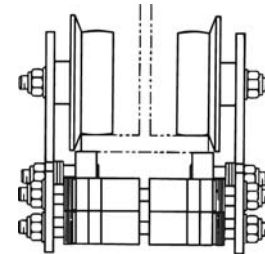
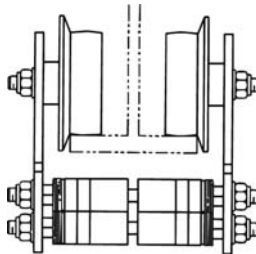

	Without Anti-Lift Rollers		With Anti-Lift Rollers	
Main Roller Diameter In. (mm)	2.5" (62)	4" (100)	2.5" (62)	4" (100)
Maximum Load Lbs. (Kg)	450 (204)	1100 (500)	450 (204)	1100 (500)
Part Number	40670	40672	40674	40676
Weight Lbs. (Kg)	23 (10.4)	33.8 (15.3)	24 (10.9)	36.2 (16.4)

Running Gear for W Beams

Steel Main Rollers, Polyurethane Tire

Running Gear

- Consists of (4) side shields with appropriate rollers, galvanized steel spacers and stainless steel fastener.
- Main rollers: *steel hub, zinc plated with permanently sealed precision ball bearings.*
- Horizontal guide and anti-lift rollers: *zinc plated steel with sealed ball bearings.*
- Operating temperatures: -22° F to 220° F.
- Running gear designed for independent side shield removal.

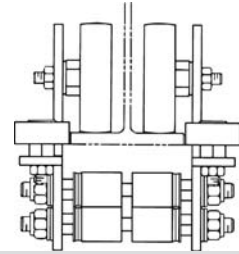
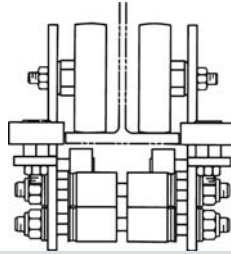

	With Horizontal Guide Rollers		With Horizontal Guide & Anti-Lift Rollers	
Main Roller Diameter In. (mm)	2.5" (62)	4" (100)	2.5" (62)	4" (100)
Maximum Load Lbs. (Kg)	315 (143)	770 (350)	315 (143)	770 (350)
Part Number	40547	40549	40552	40554
Weight Lbs. (Kg)	23.3 (10.6)	31.3 (14.2)	24.4 (11.1)	33.7 (15.3)

Ordering Instructions

How To Order Running Gear:

Running gear is assembled to the trolleys and tow trolleys at the factory. They are set to the nominal dimension of the I-beam of choice.

- Choose the appropriate running gear type and roller diameter.
- Add the corresponding suffix of the beam size to the base running gear number.

Example: 40560E = Running gear with 2.5" dia. steel main roller with horizontal guide and anti-lift rollers set for W6 x 12 I-beam.

Beam Size	Part Number Suffix	Beam Size	Part Number Suffix
W4 x 13	A*	W8 x 15	M
W5 x 16	B	W8 x 18	N
W5 x 19	C	W8 x 21	P
W6 x 9	D		
W6 x 12	E		
W6 x 16	G		
W8 x 10	L		
W8 x 13	L		

* NOTE: Suffix code C & D are not applicable for running gear with 4" dia. Main Roller.

Accessories

Step 5: Accessories / Tow Rope Assemblies

The use of tow rope or tow chain assemblies are recommended for applications where:

- ◆ Travel speed is greater than 150 FPM (45m/min)
- ◆ Acceleration is greater than 1 ft/s² (0.3m/s²)

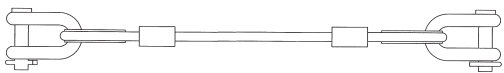

ROPE:

- ◆ Vinyl coated 7x19 galvanized steel aircraft cable 1/4" dia. (6mm)
- ◆ Overall diameter 5/16" (8mm)
- ◆ Working load: 2,800 lbs.

HARDWARE:

- ◆ Thimble galvanized steel
- ◆ Aluminum ferrule
- ◆ 7/16" galvanized steel shackle w/ roll pin

Part No.	Length Range	
	Feet	Meters
40580 A-A	up to 6.00	up to 1.82
40580 A-B	6.01 to 9.00	1.83 to 2.74
40580 A-C	9.01 to 12.00	2.75 to 3.65
40580 A-D	12.01 to 15.00	3.66 to 4.57
40580 A-E	15.01 to 18.00	4.58 to 5.48
40580 A-F	18.01 to 21.00	5.49 to 6.40

Part No.	Length Range	
	Feet	Meters
40580 A-G	21.01 to 24.00	6.41 to 7.31
40580 A-H	24.01 to 27.00	7.32 to 8.23
40580 A-J	27.01 to 30.00	8.24 to 9.14
40580 A-K	30.01 to 33.00	9.15 to 10.06
40580 A-L	33.01 to 36.00	10.07 to 10.97
40580 A-M	36.01 to 39.00	10.98 to 11.89

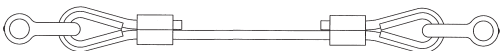

ROPE:

- ◆ Vinyl coated 7x19 galvanized steel aircraft cable 5/16" dia. (8mm)
- ◆ Overall diameter 3/8" (10mm)
- ◆ Working load: 3,900 lbs.

HARDWARE:

- ◆ Thimble galvanized steel
- ◆ Aluminum ferrule
- ◆ 7/16" galvanized steel shackle w/ roll pin

Part No.	Length Range	
	Feet	Meters
40580 B-A	up to 6.00	up to 1.82
40580 B-B	6.01 to 9.00	1.83 to 2.74
40580 B-C	9.01 to 12.00	2.75 to 3.65
40580 B-D	12.01 to 15.00	3.66 to 4.57
40580 B-E	15.01 to 18.00	4.58 to 5.48
40580 B-F	18.01 to 21.00	5.49 to 6.40

Part No.	Length Range	
	Feet	Meters
40580 B-G	21.01 to 24.00	6.41 to 7.31
40580 B-H	24.01 to 27.00	7.32 to 8.23
40580 B-J	27.01 to 30.00	8.24 to 9.14
40580 B-K	30.01 to 33.00	9.15 to 10.06
40580 B-L	33.01 to 36.00	10.07 to 10.97
40580 B-M	36.01 to 39.00	10.98 to 11.89

Tow Chain Assembly

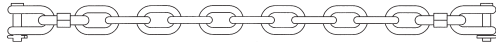

CHAIN:

- ◆ 0.25" Galvanized steel, grade 30 proof coil
- ◆ Working load: 1,250 lbs.
- ◆ Weight: 0.675 lbs. / ft.
- ◆ Travel speeds less than 150 FPM

HARDWARE:

- ◆ 0.43" Galvanized steel shackle with roll-pin
- ◆ Weight: 0.38 lbs. each

Part No.	Length Range	
	Feet	Meters
40580 C-A	up to 6.00	up to 1.82
40580 C-B	6.01 to 9.00	1.83 to 2.74
40580 C-C	9.01 to 12.00	2.75 to 3.65
40580 C-D	12.01 to 15.00	3.66 to 4.57
40580 C-E	15.01 to 18.00	4.58 to 5.48
40580 C-F	18.01 to 21.00	5.49 to 6.40

Part No.	Length Range	
	Feet	Meters
40580 C-G	21.01 to 24.00	6.41 to 7.31
40580 C-H	24.01 to 27.00	7.32 to 8.23
40580 C-J	27.01 to 30.00	8.24 to 9.14
40580 C-K	30.01 to 33.00	9.15 to 10.06
40580 C-L	33.01 to 36.00	10.07 to 10.97
40580 C-M	36.01 to 39.00	10.98 to 11.89

Length Calculation

Tow Rope / Tow Chain Length
*TRL = (**ATL + 4.25") x 1.05

**TRL = Tow Rope/Tow Chain Length **ATL = Active Travel Per Loop*

Ordering Instructions

How To Order Tow Rope / Tow Chain:

- Calculate length using the above formula.
- Using charts on pages 20 & 21, locate the appropriate length range in order to determine the proper part number.
- When ordering, specify the part number and the calculated length.

Example: Calculated tow rope length of 13.75 feet.
 5/16" diameter tow rope assembly has been chosen.
 To order specify: **40580A-D @ 13.75 feet long.**

Accessories

Shock Cord Assembly (with Two Ropes or Four Ropes)

The use of shock cord assemblies are recommended for applications where:

- ◆ Travel speed is greater than 300 FPM (100m/min).
- ◆ Acceleration is greater than 2 ft/s² (0.6m/s²).

Shock Cord Assembly with Two Ropes	
MATERIAL:	
Jacket:	Polypropylene
Cord:	Natural Rubber
Fittings:	Steel, Zinc-Plated
Hardware:	Stainless Steel

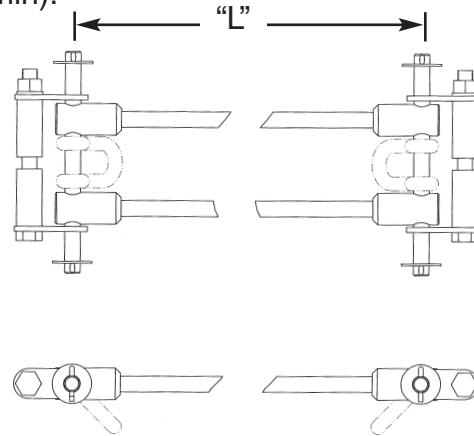

Part No.	Length Range "L"	
.62" Dia	Feet	Meters
40607 A-A	up to 2.50	up to 0.76
40607 A-B	2.51 to 4.50	0.76 to 1.37
40607 A-C	4.51 to 6.50	1.38 to 1.98
40607 A-D	6.51 to 8.50	1.99 to 2.59
40607 A-E	8.51 to 10.50	2.60 to 3.20
40607 A-F	10.51 to 12.50	3.21 to 3.81

Part No.	Length Range "L"	
.62" Dia	Feet	Meters
40607 A-G	12.51 to 14.50	3.82 to 4.42
40607 A-H	14.51 to 16.50	4.43 to 5.03
40607 A-J	16.51 to 18.50	5.04 to 5.64
40607 A-K	18.51 to 20.50	5.65 to 6.25
40607 A-L	20.51 to 22.50	6.26 to 6.85
40607 A-M	22.51 to 24.50	6.86 to 7.47

Shock Cord Assembly with Four Ropes	
MATERIAL:	
Jacket:	Polypropylene
Cord:	Natural Rubber
Fittings:	Steel, Zinc-Plated
Hardware:	Stainless Steel

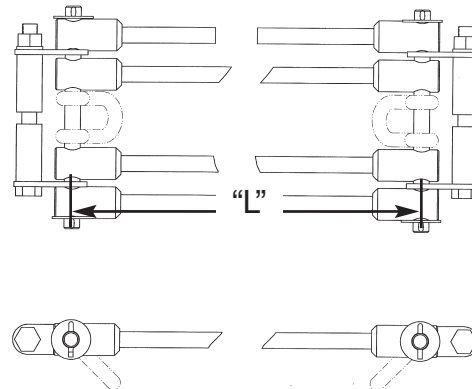

Part No.	Length Range "L"	
.62" Dia	Feet	Meters
40607 B-A	up to 2.50	up to 0.76
40607 B-B	2.51 to 4.50	0.76 to 1.37
40607 B-C	4.51 to 6.50	1.38 to 1.98
40607 B-D	6.51 to 8.50	1.99 to 2.59
40607 B-E	8.51 to 10.50	2.60 to 3.20
40607 B-F	10.51 to 12.50	3.21 to 3.81

Part No.	Length Range "L"	
.62" Dia	Feet	Meters
40607 B-G	12.51 to 14.50	3.82 to 4.42
40607 B-H	14.51 to 16.50	4.43 to 5.03
40607 B-J	16.51 to 18.50	5.04 to 5.64
40607 B-K	18.51 to 20.50	5.65 to 6.25
40607 B-L	20.51 to 22.50	6.26 to 6.85
40607 B-M	22.51 to 24.50	6.86 to 7.47

Replacement Shock Cords

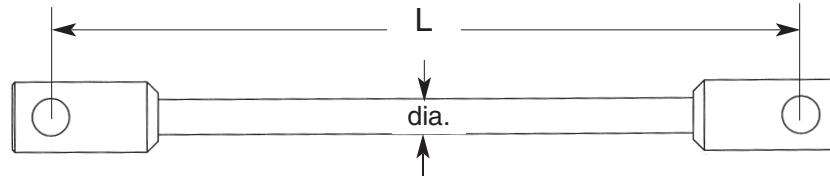

0.5" D I A	Part No.	Length Range	
		Feet	Meters
	40656-A	up to 2.50	up to 0.76
	40656-B	2.51 to 4.50	0.76 to 1.37
	40656-C	4.51 to 6.50	1.38 to 1.98
	40656-D	6.51 to 8.50	1.99 to 2.59
	40656-E	8.51 to 10.50	2.60 to 3.20
	40656-F	10.51 to 12.50	3.21 to 3.81

Part No.	Length Range	
	Feet	Meters
40656-G	12.51 to 14.50	3.82 to 4.42
40656-H	14.51 to 16.50	4.43 to 5.03
40656-J	16.51 to 18.50	5.04 to 5.64
40656-K	18.51 to 20.50	5.65 to 6.25
40656-L	20.51 to 22.50	6.26 to 6.85
40656-M	22.51 to 24.50	6.86 to 7.47

0.62" D I A	Part No.	Length Range	
		Feet	Meters
	40657-A	up to 2.50	up to 0.76
	40657-B	2.51 to 4.50	0.76 to 1.37
	40657-C	4.51 to 6.50	1.38 to 1.98
	40657-D	6.51 to 8.50	1.99 to 2.59
	40657-E	8.51 to 10.50	2.60 to 3.20
	40657-F	10.51 to 12.50	3.21 to 3.81

Part No.	Length Range	
	Feet	Meters
40657-G	12.51 to 14.50	3.82 to 4.42
40657-H	14.51 to 16.50	4.43 to 5.03
40657-J	16.51 to 18.50	5.04 to 5.64
40657-K	18.51 to 20.50	5.65 to 6.25
40657-L	20.51 to 22.50	6.26 to 6.85
40657-M	22.51 to 24.50	6.86 to 7.47

Length Calculation

Shock Cord Length
*SCL = **TRL x 0.70

SCL** = Shock Cord Length *TRL** = Tow Rope/Tow Chain Length

Ordering Instructions

How To Order Shock Cord:

- Calculate length using the above formula.
- Using charts on pages 22 & 23, locate the appropriate length range in order to determine the proper part number.
- When ordering, specify the part number and the calculated length.

Example: Calculated shock cord length of 7.7 feet.
1/2" diameter shock cord assembly has been chosen.
To order specify: **40590A-D @ 7.7 feet long.**

Accessories

Round Cable Organizers

Recommended for systems in order to prevent the cables within the loops from becoming tangled or caught during operation. Depending on the application, either one or two per loop may be required. Consult factory for further information.

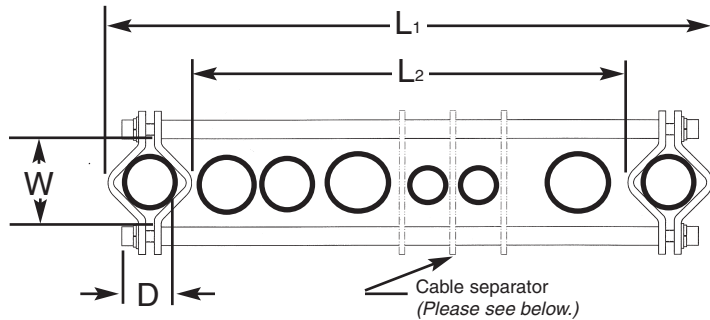

MATERIAL:

Clamps: Steel, Zinc-Plated
 Rods: Stainless Steel
 Hardware: Stainless Steel

Part Number	"D" Cable Dia. Range		L1		L2		W		Weight	
	Inches	mm	Inches	mm	Inches	mm	Inches	mm	Lbs.	Kg.
40600A	up to .75	up to 20	15.2	385	13.1	332	1.3	34	4.1	1.9
40600B	up to .75	up to 20	28.5	725	26.5	672	1.3	34	5.6	2.6
40600C	.75 - 1.00	20 - 26	15.5	394	12.8	324	1.7	42	4.3	1.9
40600D	.75 - 1.00	20 - 26	28.9	734	26.1	664	1.7	42	5.8	2.6
40600E	1.00 - 1.22	26 - 31	15.8	402	12.4	315	2.0	51	4.4	2.0
40600F	1.00 - 1.22	26 - 31	29.2	742	25.8	655	2.0	51	5.9	2.7
40600G	1.22 - 1.42	31 - 36	16.1	409	12.1	308	2.1	53	4.5	2.1
40600H	1.22 - 1.42	31 - 36	29.5	749	25.5	648	2.1	53	6.0	2.7
40600J	1.42 - 1.65	36 - 42	16.4	416	11.9	301	2.4	60	4.6	2.1
40600K	1.42 - 1.65	36 - 42	29.8	756	25.2	641	2.4	60	6.2	2.8
40600L	1.65 - 1.89	42 - 48	16.7	425	11.5	292	2.7	69	4.8	2.2
40600M	1.65 - 1.89	42 - 48	30.1	765	24.9	632	2.7	69	6.3	2.9

Cable Separators

To be used with round cable organizers listed above. If the sum of the diameters of two adjacent cables within the loop is equal to or less than the dimension "W", a cable separator must be installed to prevent cables from becoming tangled within the loop.

Part Number	Ref Organizer Part Number
40608 A	40600 A & B
40608 B	40600 C & D
40608 C	40600 E & F
40608 D	40600 G & H
40608 E	40600 J & K
40608 F	40600 L & M

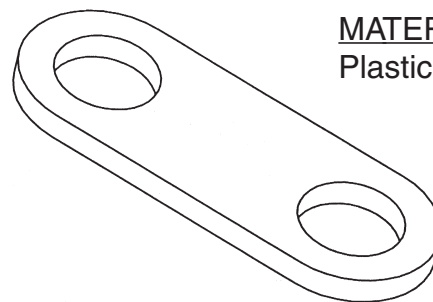

MATERIAL:
 Plastic

YOUR SINGLE SOURCE FOR MOBILE ELECTRIFICATION



You'll find Insul-8 products in use everywhere from irrigation systems and manufacturing plants in the heartland of the United States to public transportation systems in Malaysia.

Industrial Electric Reels, Inc., began in 1924 with the founding of Industrial Electric Works (IEW), an electrical contractor based in Omaha, Nebraska. After World War II, IEW began the manufacture of electric cable reeling equipment and started IER as an operating division in 1948. IER's first cable reel, the hand rewind Series 102 PORT-O-REEL, was quickly followed by light-duty spring retractable cable reels. IER pioneered the development of cable reeling devices and slip rings. Soon the business expanded to larger, custom built motor driven reels and custom engineered slip rings. IER's reputation spread as a quality manufacturer of reels running the gamut from small commercial duty reels to large custom built reels for the most demanding applications such as container cranes, stacker/reclaimers and bulk material ship loaders and unloaders.

Insul-8 Corporation has been a pioneer in providing safety-covered metal conductor systems for the material handling industry since 1944. Insul-8 was the first company to design and produce a stainless steel capped aluminum conductor and the only manufacturer of such a product for almost 20 years. Today, there are over 20 million meters (nearly 12,500 miles) of Insul-8 contact conductors and tens of thousands of collecting devices throughout the world. Every major port in the United States currently uses Insul-8's aluminum/stainless steel contact conductors on container cranes due to the dependability of the bar under the most severe conditions. Insul-8's festoon systems range from the smallest box-track systems to our most rugged Heavy-Duty Festoon. Insul-8's festoons are known for their safe and efficient operation in which large numbers of conductors can be handled in minimum space.

Insul-8 has been in the business of supplying power from stationary sources to mobile systems for 60 years. Insul-8's cable reels, slip rings, conductor bar, festoon systems, pendants and radio controls are used in a wide variety of applications ranging from material handling and mass transit systems to water treatment plants and performing arts theaters.

As it has been for the last 60 years and always will be, "conducting" business will continue to be our only business.

In December 1997, after a nine month endeavor, Insul-8 Corporation became ISO 9001 certified for the design and manufacture of our entire line of mobile electrification products in both of our U.S.A. plants in Omaha, Nebraska, and Harlan, Iowa.

Since our inception in 1902, Insul-8 Corporation's parent company, Delachaux S.A., has been a leading international presence in the business of providing mobile electrification. As the Delachaux arm in North and South America, Insul-8 Corporation (formerly sister companies Insul-8 and Industrial Electric Reels, Inc. - a.k.a. IER) carries on this tradition of innovation and excellence. Insul-8 and IER became part of the Delachaux Group in 1975 and officially became one company on December 31, 1996. Each company has its own rich history.



Conductix products can electrify items from small industrial machinery to large amusement park rides and international public transit systems.

- ◆ cable and hose reels ◆ conductor bar systems ◆ cable festoon systems ◆
- ◆ slip rings ◆ pendant stations ◆ radio controls ◆

www.conductix.us

CONDUCTIX

INSUL 8

© DELACHAUX GROUP

Specifications may change without notice. All products F.O.B. Omaha, NE, or Harlan, IA, unless otherwise specified.

Terms & Conditions

CONDUCTIX INC.

The technical data and images which appear in this manual are for informational purposes only. NO WARRANTIES, EXPRESSED OR IMPLIED, INCLUDING WARRANTIES OF MERCHANTABILITY OR FITNESS FOR A PARTICULAR PURPOSE, ARE CREATED BY THE DESCRIPTIONS AND DEPICTIONS OF THE PRODUCTS SHOWN IN THIS MANUAL. CONDUCTIX makes no warranty (and assumes no liability) as to the function of equipment or the operation of systems built according to customer design; or of the ability of any of its products to interface, operate or function with any portions of customer systems not provided by CONDUCTIX.

Seller agrees to repair or exchange the goods sold hereunder necessitated by reason of defective workmanship, and material discovered and reported to Seller within one year after shipment of such goods to Buyer.

Except where the nature of the defect is such that it is appropriate in Seller's judgement to effect repairs on site. Seller's obligation hereunder to remedy defects shall be limited to repairing or replacing (at Seller's option), FOB point of original shipment by Seller, any part returned to Seller at the risk and cost of Buyer. Defective parts replaced by Seller shall become the property of Seller.

Seller shall only be obligated to make such repair or replacement of the goods which have been used by Buyer in service recommended by Seller and altered only as authorized by Seller. Seller is not responsible for defects which arise from improper installation, neglect, or improper use or from normal wear and tear.

Additionally, Seller's obligation shall be limited by the manufacturer's warranty, (and shall not be further warranted by Seller) for all parts procured from others according to published data, specifications or performance information not designed by or for Seller.

Seller further agrees to replace, or at Seller's option to provide a refund of the sales price of any goods that did not conform to applicable specifications or which differ from that agreed to be supplied which non-conformity is discovered and forthwith reported to Seller within thirty (30) days after shipment to Buyer. Seller's obligation to replace or refund the purchase price for non-conforming goods shall arise once Buyer returns such good FOB point of original shipment by Seller at the risk and cost of Buyer. Goods replaced by Seller shall be come property of Seller.

There is no guarantee or warranty as to anything made or sold by Seller, or any service performed, except as to title and freedom from encumbrances, and except as herein expressly stated and particularly without limiting the foregoing. There is no guarantee or warranty, express or implied, of merchantability or of fitness for any particular purpose or against claim of infringement or the like.

Seller makes no warranty (and assumes no liability) as to function of equipment or operation of systems built to Buyer's design or of the ability of any goods to interface, operate or function with any portions of Buyer's system not provided by Seller.

Seller's liability on any claim; whether in contract (including negligence) or otherwise, for any loss or damage arising out of, connected with, or resulting from the manufacture, sale, delivery, resale, repair, replacement or use of any products or, services shall in no case exceed the price paid for the product or services or any part thereof which give rise to the claim. In no event shall Seller be liable for consequential, special, incidental or other damages, nor shall Seller be liable in respect to personal injury or damage to property on the subject matter hereof unless attributable to gross misconduct of Seller, which shall mean an act of omission by Seller demonstrating reckless disregard of the foreseeable consequences thereof.

Seller is not responsible for incorrect choice of models or where products are used in excess of their rated and recommended capacities and design functions or under abnormal conditions. Seller assumes no liability for loss of time, damage or injuries to property or persons resulting from the use of Seller's products. Buyer shall hold Seller harmless from all liability, claims, suits and expenses in connection with loss or damage resulting from operation of products or utilization of services, respectively, of Seller and shall defend any suit or action which might arise there from Buyer's name - provided that Seller shall have the right to elect to defend any such suit or action for the account of Buyer. The foregoing shall be the exclusive remedies of the buyer and all persons and entitles claiming through the Buyer.

Festoon Systems In Action

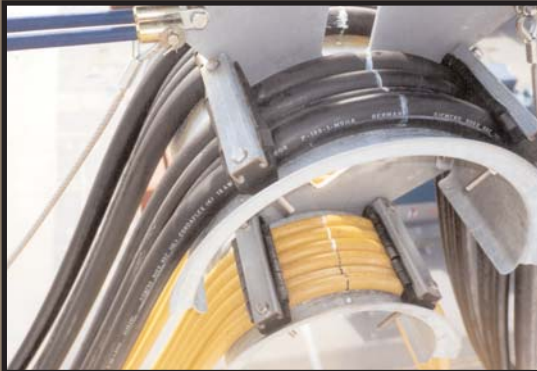

CONDUCTIX Worldwide



Headquarters

DELACHAUX S.A

119 Avenue Louis Roche - BP152
92231 Gennevilliers Cedex
FRANCE
Tel: +33 (0) 1 46 88 15 00
Fax: +33 (0) 1 46 88 15 01
www.delachaux.fr
delachomgt@delachaux.fr

CONDUCTIX OPERATIONS

119 Avenue Louis Roche - BP152
92231 Gennevilliers Cedex
FRANCE
Tel: +33 (0) 1 46 88 15 13
Fax: +33 (0) 1 46 88 15 10
conductix@delachaux.fr
www.conductix.com

Countries where we are represented:

Algeria, Argentina, Austria, Bahrain, Bolivia, Brazil, Bulgaria, Camerouns, Chile, China, Columbia, Congo, Ivory Coast, Croatia, Czechia, Denmark, U.A.S., Ecuador, Egypt, Finland, Gabon, Greece, Guatemala, Guinea, Honduras, Hungary, Indonesia, India, Iraq, Iran, Ireland, Isreal, Japan, Jordania, Korea, Kuwait, Lebanon, Madagascar, Malaysia, Mali, Mauritania, Mexico, Morocco, Netherlands, New Zealand, Niger, Nigeria, Norway, Pakistan, Panama, Paraguay, Peru, Philippines, Poland, Portugal, Romania, Russia, Saudi Arabia, Senegal, Singapore, Slovakia, South Africa, Spain, Sweden, Switzerland, Syria, Thailand, Tunisia, Turkey, Uruguay, Venezuela, Viet-Nam...

AUSTRALIA

CONDUCTIX Pty. Ltd. (Insul-8)
Dandenong
Tel: +(61) 3 97 06 88 44
Fax: +(61) 3 97 94 92 98
info@conductix.com.au
www.conductix.com.au

BENELUX

CONDUCTIX Benelux
Brussels
Tel: +(32) (0) 2 469 25 60
Fax: +(32) (0) 2 469 29 35
info@conductix.be
www.conductix.be

CANADA

CONDUCTIX Corp. (Insul-8)
St Jerome
Tel: (450) 565-9900
Fax: (450) 432-6985
infocanada@conductix.us
www.conductix.us

CHINA

CONDUCTIX Ltd (Han-Fa)
Wuhan
Tel: +(86) 27 83 49 99 88
Fax: +(86) 27 83 49 99 89
info@conductix.cn
www.conductix.cn

FRANCE

CONDUCTIX (Delachaux)
Belley
Tel: +(33) (0) 4 79 42 50 00
Fax: +(33) (0) 4 79 42 50 05
infoconductix@conductix.fr
www.conductix.fr
Gennevilliers
Tel: +(33) (0) 1 46 88 15 23
Fax: +(33) (0) 1 46 88 15 21
infoconductix@conductix.fr
www.conductix.fr

GERMANY / AUSTRIA

CONDUCTIX GmbH
Offenbach / Main
Tel: +(49) 69 98 40 23 0
Fax: +(49) 69 98 40 23 99
info@conductix.de
www.conductix.de

ITALY

CONDUCTIX Srl (Comes)
Milan
Tel: +39 (0) 39 607 431
Fax: +39 (0) 39 607 43292
Turin
Tel: +39 (0) 11 45 09 007
Fax: +39 (0) 11 42 41 008
info@conductix.it
www.conductix.it

MEXICO

CONDUCTIX S.de R.L. de C.V. (Insul-8)
Monterrey
Tel: +(52) 811 090 9013
Fax: +(52) 811 090 9014
infomexico@conductix.us
www.conductix.com.mx

UNITED KINGDOM

CONDUCTIX Ltd (Insul-8)
Salford
Tel: +(44) 161 848 01 61
Fax: +(44) 161 873 70 17
info@conductix.co.uk
www.conductix.co.uk

UNITED STATES

CONDUCTIX, Inc. (Insul-8)
Omaha, NE
Tel: +(1) 402 339 9300
Fax: +(1) 402 339 9627
info@conductix.us
www.conductix.us
Harlan, IA
Tel: + (1) 402 339 9300
Fax: + (1) 402 339 9627
info@conductix.us
www.conductix.us