

TETHER TRACK™

Rigid Rail Anchor System Styles

MONORAIL SYSTEMS

For applications where a worker needs to travel in a straight line, Gorbel monorail anchor systems offer strength and mobility along a single axis.

BRIDGE SYSTEMS

Gorbel bridge anchor systems provide maximum coverage when a worker's duties require movement along the X and Y axis. The lightweight, high strength aluminum bridge effortlessly follows as the worker moves within the rectangular coverage area.

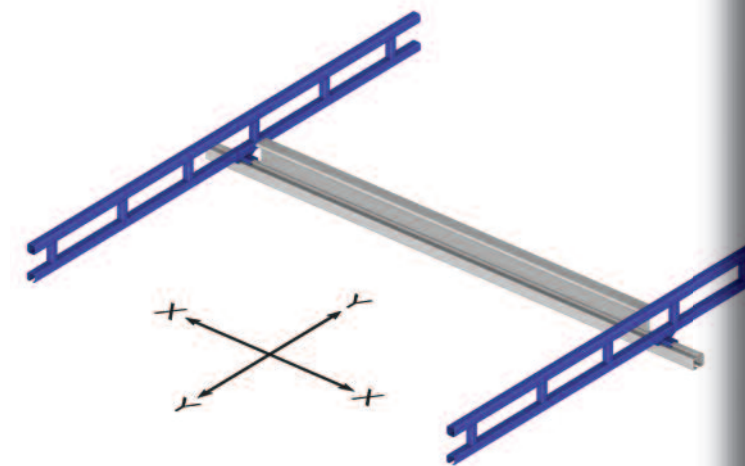

GORBEL
A CLASS ABOVE
www.gorbel.com



GORBEL
A CLASS ABOVE
www.gorbel.com

FOR MORE INFORMATION

Your authorized Gorbel® dealer can give you more information on what makes Gorbel's Ergonomic Work Station Cranes and other material handling products "A Class Above."

BRIDGE CRANES

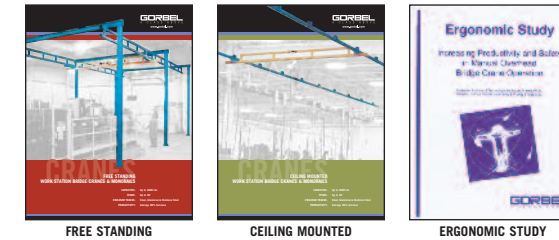

ERGONOMIC LIFTING



JIB CRANES



SPECIALTY PRODUCTS

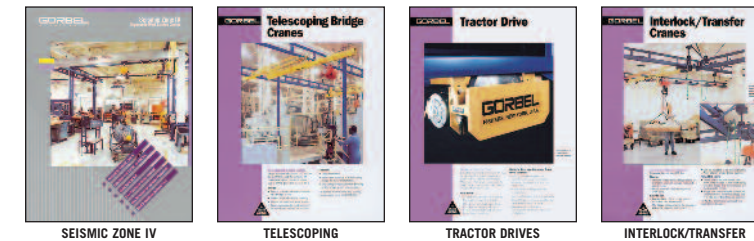

FAIL ARREST

TETHER TRACK™ RIGID RAIL ANCHOR SYSTEMS

GORBEL®
600 Fishers Run
PO Box 593
Fishers, NY 14453 USA

T 800.821.0086
T 585.924.6262
F 585.924.6273
E info@gorbel.com

DESIGN: Built to withstand 900 pound maximum arresting force

MOUNTING STYLE: Ceiling mounted or free standing monorail & bridge anchor systems

LENGTHS: Unlimited monorail & runway lengths, 15' spans for bridge anchor systems

Gorbel Fall Arrest Anchor Systems

For over 30 years, Gorbel has been an innovator and leader in ergonomic overhead lifting solutions. We have designed and manufactured a variety of rail technologies and lifting devices that have set the industry standard for quality, ease of use and return on investment. With our innovative rail technology and years of experience with overhead solutions, we offer durable rigid rail anchor systems as a way to reduce fall-related injuries.

DID YOU KNOW?

- Required by OSHA: OSHA 1926 requires fall protection for employees who work at height, defined as 4' per OSHA 1910 General Industry Standards, 5' per OSHA 1918 Long Shoring Standards, and 6' per OSHA Construction Standards.
- The U.S. Department of Labor lists falls as one of the leading causes of traumatic occupational death.
- Falls cost businesses over \$170 billion each year in medical costs, wages, and lost productivity.
- There are an average of 2 fall-related deaths per day nationwide.

WHAT IS A FALL ARREST SYSTEM?

A fall arrest system is an active means of protecting workers from falls in elevated work environments. A complete fall arrest system includes an anchor system, a body harness, and a connector—such as a shock-absorbing lanyard or a self-retracting lifeline (SRL). The complete system, using Gorbel's Tether Track™ as your anchor, provides a worker with a high degree of mobility and freedom to perform a task while stopping falls to lower levels.

WHY CHOOSE A GORBEL TETHER TRACK™ ANCHOR SYSTEM?

Gorbel fall arrest anchor systems are a reliable, cost-effective way to reduce the risk of injury in elevated work environments. Standard systems are designed to support multiple workers, each weighing up to 310 pounds with tools. Heavier worker systems can also be custom engineered.

The building block for Gorbel's rigid anchor system is our enclosed track design, which is engineered for easy movement. The cold rolled steel track keeps dirt and dust from settling on the rolling surface, allowing for smoother, more consistent ease of movement than an I-Beam with no need for cleaning or maintenance of the track.

The track also features a running flange with a 2-degree taper to keep the trolley centered. That allows the trolley and attached lanyard to easily follow the worker, rather than forcing them to pull free a trolley that has become stuck.

Our rigid rail anchor systems are designed by qualified engineers to exceed the OSHA 1926 Subpart M Construction standard as well as ANSI Z359 Fall Protection Code using a maximum off-vertical loading of 30-degrees. This strict design criteria means that our track supports the full impact of falls vertically and also at a 30-degree angle. That's important for applications where the risk is to fall off the side of an object rather than straight down.

www.gorbel.com
800.821.0086

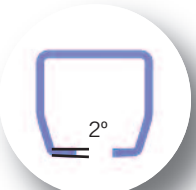

SIDE-BY-SIDE: Rigid Rail Anchor Systems vs. Wire Rope

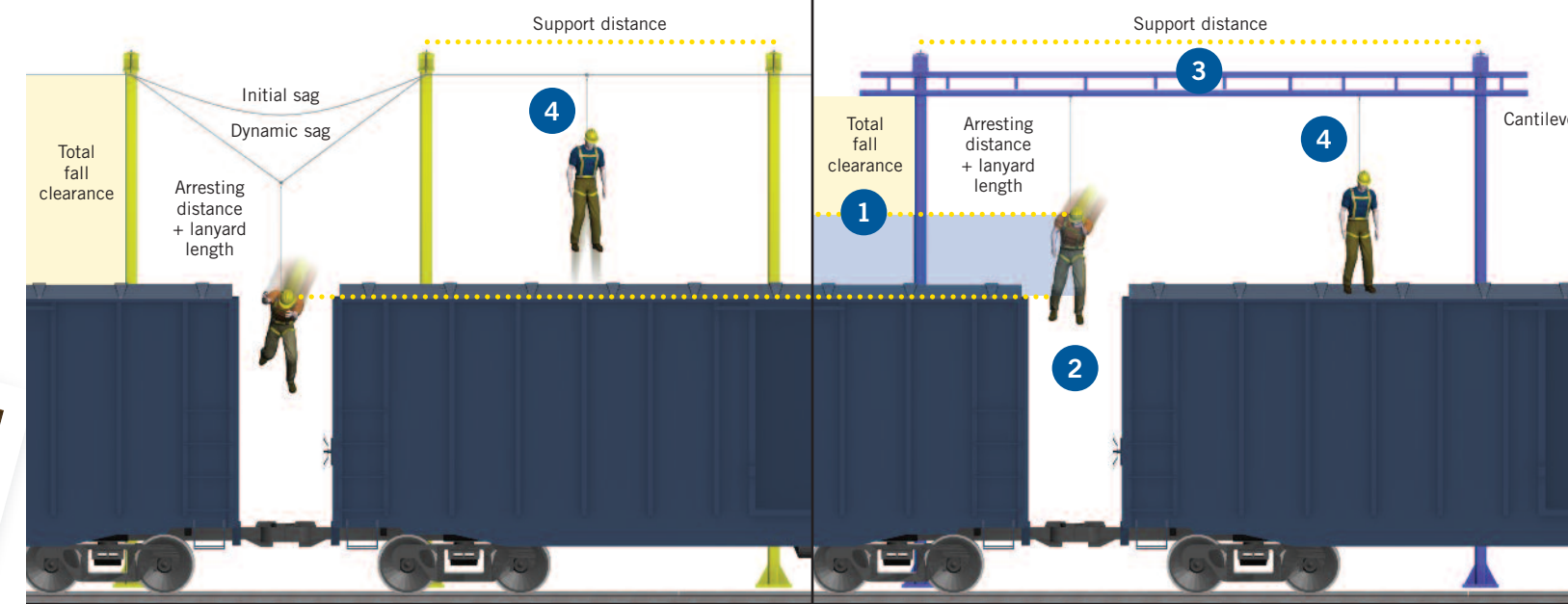

Compared to wire rope anchor systems, a rigid rail system by Gorbel offers:

- 1 LESS FALL CLEARANCE DISTANCE:** Wire rope systems require additional fall clearance distances due to the initial sag of the wire and dynamic sag, or the sag and stretch of rope between adjacent support points, before the wire rope has enough tension to stop the fall (as seen in figure 1). Gorbel's rigid rail stops the fall sooner by eliminating any sag (as seen in the blue shaded area of figure 2), stopping the fall in a much shorter distance than wire rope. By eliminating initial and dynamic sag distance, a Gorbel rigid rail anchor system is the best option for fall arrest in low headroom applications. With a shorter overall fall distance than wire rope, less clearance is required from the anchor point to the floor below.
- 2 REDUCED RISK OF SECONDARY FALL INJURIES:** Injuries occurring after the fall, such as swinging into obstacles, are minimized with an anchorage system that stays firm and minimizes total fall distance. When a worker falls on a wire rope system, the wire's sag will make the trolley or pulley slide to the center of the nearest two supports, creating a risk for the fallen worker to collide with nearby obstacles as it centers.
- 3 LONGER DISTANCES BETWEEN SUPPORTS:** A rigid anchor system allows you to cover greater lengths between supports. This reduces both material and installation costs for your system, and also makes installation easier with fewer restrictions for where supports will be located.
- 4 SAFER WORK FOR MULTIPLE PEOPLE:** When a worker falls on a wire rope system, any slack on the wire is eliminated. The result could be a sudden pull on the rope that can have a jarring effect on other workers on the same system, putting them at risk. Rigid rail systems provide uninterrupted protection for additional workers on the same system without putting them in harm's way. In the event of one worker's fall, the enclosed track will not bend or deflect. That allows additional workers to continue moving freely and safely.

Anchor System Components

CHOOSING THE RIGHT TRACK

The following tables are intended to assist you in choosing the best track for your application. ANSI defines one worker as an individual with tools that does not exceed 310 lbs. For applications that require a worker and tools exceeding 310 lbs, please consult Gorbel for a custom engineered system. All systems listed are designed for components that are rated for the industry standard 900 pounds maximum arresting force (MAF). MAF is defined as the shock force the body feels when decelerating from a fall. For applications with higher potential force, systems can be custom designed as high as the OSHA specified 1800 lbs MAF.



PLAIN TRACK

Plain enclosed steel track provides smooth motion with the benefit of offering the most headroom of any track style.

Track Series	MAXIMUM SUPPORT DISTANCES ¹		MAXIMUM CANTILEVER ²	
	1 Worker	2 Workers	1 Worker	2 Workers
F500	12 feet	7 feet	3 feet	2 feet
F1000	18 feet	12 feet	4.5 feet	3 feet

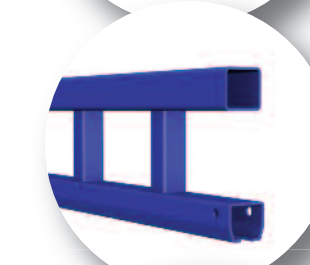

TRUSSED TRACK

Single trussed track allows for the longest possible spans between supports, reducing hardware and installation costs.

Track Series	MAXIMUM SUPPORT DISTANCES ¹		MAXIMUM CANTILEVER ²	
	1 Worker	2 Workers	1 Worker	2 Workers
F500S	20 feet	16 feet	5 feet	4 feet
F500SL	25 feet	18 feet	6 feet	5 feet
F500SLX	30 feet	22 feet	6 feet	6 feet



DUAL TRUSSED TRACK

The dual-track enables one worker to pass by another on a monorail system without unsafely disconnecting.

Track Series	MAXIMUM SUPPORT DISTANCES ¹	MAXIMUM CANTILEVER ²
F500SLD	35 feet	6 feet

¹ For longer support distances or custom applications, contact Gorbel Inside Sales.

² Cantilever is the overhang distance from the system's last support.

Intended for indoor use. For outdoor applications, contact Gorbel Inside Sales.

Tether Trolleys™

Gorbel's Tether Trolleys™ were engineered specifically for fall protection applications to provide fluid movement and stability. The trolley uses DURACOMP4 wheels, a proprietary material that delivers unmatched durability and consistent long term performance. To match the 2-degree taper of the lower running flange, wheels are also tapered 2-degrees to help keep the trolley centered in the track for effortless movement.

The swivel eye secures the lanyard or SRL, allowing free movement beneath the trolley and prevents twisting of the lanyard or SRL.

The three wheel design of the monorail trolley prevents binding inside the track, even when side loaded up to 30-degrees. This means that as the workers moves, the trolley moves as well.

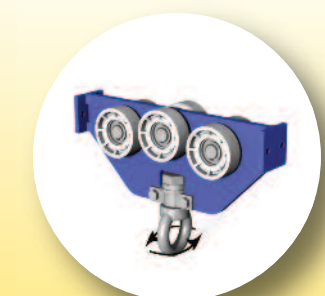

www.gorbel.com
800.821.0086